

APA MAGAZINE

The Magazine for the Polygraph Professional

Keeler Patent P. 76

Polygraph in Agent Interrogation P.49

September/October 2015

Volume 48,5

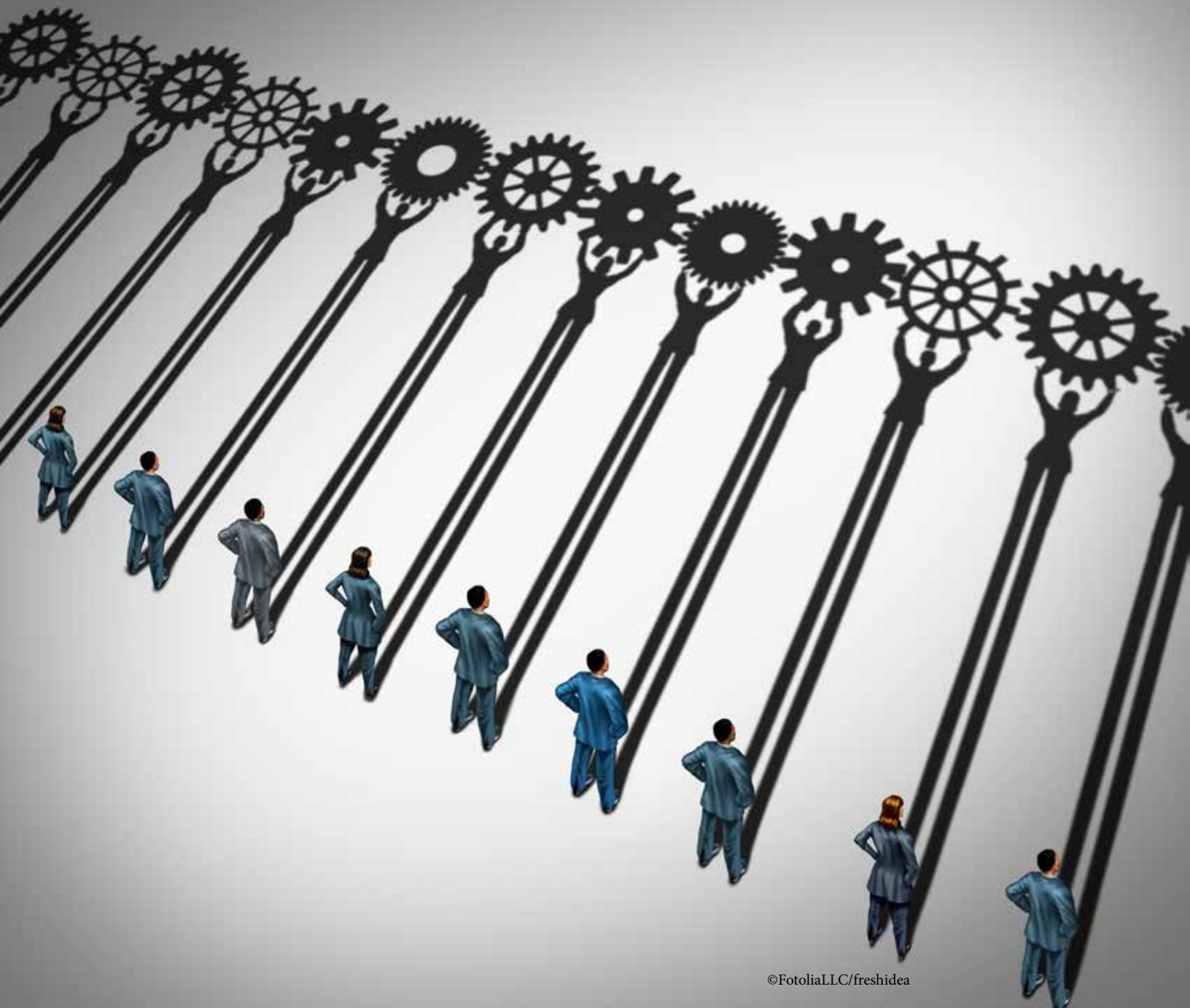

COMPREHENSIVE POLYGRAPH SOLUTIONS

from Lafayette Instrument Company



LXSOFTWARE 11.5.1

LXSoftware can be configured to use only the essentials required for polygraph testing, or extended to satisfy the most complex test environments and situations. LXSoftware offers unparalleled ease-of-use and proven reliability; it comes with POLYSCORE® and OSS-3 Scoring Algorithms, as well as the following features:

- **The best EDA solutions available** with six EDA options (GSR or GSC: manual, detrended, and automatic)
- Virtual Pulse Amplitude sensor: provides a visual comparison of the pulse amplitude changes in the PPG data
- ESS Report Generator: uses the built-in score sheet to formulate a printable report including a summary conclusion
- Customizable Personal History, Series forms, and PF Types
- Advanced Audio/Video: up to 16 configurable camera views
- Integrated language support for Spanish, Dari, and Russian
- Windows® 10 Compatible with Mac support available via Parallels® or other virtualization software
- No Software Maintenance Agreement or fees for updates; software updates are available on our website: www.lafayettepolygraph.com/software

LX5000 SYSTEM

Designed as a robust system that is significantly smaller in size than the LX4000, our standard LX5000 System simultaneously records nine channels and includes many features:

- Data transfer rate up to 360 samples per second across all channels
- 24-bit analog to digital conversion
- Up to 9 additional channels (18 total)
- Dedicated channels for seat, arm, and feet activity
- Extended measurement ranges
- Selectable GSR or GSC EDA channel
- Dedicated PPG Plethysmograph channel
- Operates with proven, state-of-the-art, LXSoftware
- UL 94 V-0 rated
- CE and ASTM tested for safety and durability
- 3 year warranty and lifetime technical support



Contents

Contributors to this issue

Tuvya T. Amsel
George Baranowski
Thomas Baum
Chester Crawford
Gary F. Davis
Steven Duncan
Hugh S. Fullerton
Walt Goodson
Christopher D. Green
Mark Handler
Lisa Jacocks
Leonard Keeler
Donald Krapohl
Raymond Nelson
Patrick O'Burke
Pam Shaw
Carl Turner
Paul Wood

Deadlines

This issue closed on
September 30, 2015.

Deadline for November/December 2015
issue is November 15, 2015.

Submission of Articles

The *APA Magazine* is published by the American Polygraph Association. All views, opinions and conclusions expressed in this magazine are those of the authors, and do not necessarily reflect the opinion and/or policy of the APA or its leadership. References in this magazine to any specific commercial products, process, or service by trade name, trademark, manufacturer or otherwise, does not necessarily constitute or imply endorsement, recommendation, or favoring by the APA or its leadership.

Appearance of advertisements in this magazine does not constitute or imply endorsement, recommendation

Membership News

- 4 APA Board of Directors
- 9 In Memoriam
- 6 Buy and Sell
- 45 Employment
- 83 50th APA Seminar Photo Memoirs

Training & Seminars

- 6 Polygraph Examiner Training Schedule
- 5 APA Virginia Beach Seminar Registration Form
- 8 New Mexico Seminar Registration Form
- 111 Polygraph Schools Accredited by The APA

From the Board

- 11 President's Message
- 14 Board of Directors' Reports
- 23 Anti-trust Compliance Program
- 39 APA Non-Profit Certificate
- 44 Public Censure

Regular Features

- 46 Practicum - *Confirmatory Polygraph Testing* by Tuvya T. Amsel
- 65 Polygraph Abroad: *Destination Great Britain* by Paul Woods

Special Features

- 45 *Mosso Respiration Recorder 1898* by Donald Krapohl
- 49 *The Polygraph In Agent Interrogation* by Chester C. Crawford
- 58 Cheat Sheet for Using Normative Data and Empirical Scoring System by Ray Nelson and Mark Handler
- 59 *Why Babe Ruth is Greatest Home-Run Hitter* by Hugh S. Fullerton
- 69 Five Minute Science Lesson: *Types of Scientific Studies* by Raymond Nelson
- 73 Keeler Patent *Aparatus for Recording Arterial Blood Pressure*
- 79 Book Review *Donald Krapohl and Pamela Shaw's Fundamentals of Polygraph Practice* by Mark Handler
- 101 Polygraph Testing as a Singles-Subject Scientific Experiment by Raymond Nelson

or favoring by the APA and the APA makes no warranty, express or implied, regarding the accuracy, completeness, or usefulness of any information, product, process or service made a subject of such advertisement. Advertising and Editorial address is editor@polygraph.org. Subscription address is: APA, P.O. Box 8037, Chattanooga, TN 37414-0037. The *APA Magazine* is published six times per year and is available in electronic format only. Address and e-mail changes/updates should be sent to: APA, P.O. Box 8037, Chattanooga, TN 37414-0037, or manager@polygraph.org. E-mail notification is sent to subscribers when the latest publication is available. The APA webmaster is not responsible for issues not received because of improper address information. Submission of polygraph-related articles should be sent to: Mark Handler, editor@polygraph.org.

POLYGRAPH COURSE TUITION \$4795 !



2016 Schedule

Basic Examiner

- ◆ Feb - May (San Antonio)
- ◆ July - Sept. (Las Vegas)

Validated Interview

- ◆ Check our website
- ◆ Call to host a course

JPCOT/PCSOT

- ◆ May (San Antonio)
- ◆ October (Las Vegas)

TDLR CE Course

- ◆ Contact us for scheduling

- Fully accredited by the American Polygraph Association and approved by the Texas Department of Licensing and Regulation and the American Association of Police Polygraphists. *
- Demonstrated past performance in polygraph training. Our instructors have more than 100 years of combined field experience.
- Modern & comfortable classroom with audio/video monitored practice labs.
- Forty hours of training in our *Validated Interview Technique* included during the course.
- Low ratio of students to instructors creates personalized instruction.
- Comfortable and affordable hotels nearby.
- Our Post Conviction Sex Offender Training follows each Basic Course.
- Quality Control support for students following training.

The successful completion of an APA accredited polygraph program is only one of the necessary prerequisites for membership in the American Polygraph Association or other organizations.

Register on line at: www.thepolygraphinstitute.com

We accept Visa, MasterCard, Discover and business checks.
 22610 US Hwy 281 N, Suite 206, San Antonio TX 78258
 (210) 377-0200 info@thepolygraphinstitute.com



APA BOARD OF DIRECTORS 2015-2016

President

Walt Goodson
president@polygraph.org

President - Elect

Patrick O'Burke
president-elect@polygraph.org

Chairman of the Board

Raymond Nelson
chair@polygraph.org

Vice President – Government

Darryl Starks
vp-government@polygraph.org

Vice President – Private

Gary F. Davis
vp-private@polygraph.org

Vice President – Law Enforcement

Daniel Violette
vp-lawenforcement@polygraph.org

Director

George Baranowski
1912 E. US Hwy 20, Suite 202
Michigan City, IN 46360
directorbaranowski@polygraph.org

Director

Barry Cushman
109 Middle Street
Portland, ME 04101
E-mail: directorcushman@polygraph.org

Director

Donnie Dutton
directordutton@polygraph.org

Director

Jamie McCloughan
directormccloughan@polygraph.org

Director

Steve Duncan
directorduncan@polygraph.org

Ex Officio Members

National Office Manager

Lisa Jacocks
P.O. Box 8037
Chattanooga, TN 37414-0037
manager@polygraph.org

Treasurer

Chad Russell
treasurer@polygraph.org

General Counsel

111 S. Tejon St., Suite 545
Colorado Springs, CO 80903-2245
generalcounsel@polygraph.org

Editor-in-Chief

Mark Handler
editor@polygraph.org

Seminar Chair

Michael Gougler
seminarchair@polygraph.org



**AMERICAN POLYGRAPH ASSOCIATION (APA)
CONTINUING EDUCATION SEMINAR
CO-SPONSOR – VIRGINIA POLYGRAPH ASSOCIATION
ADVANCED REGISTRATION IS REQUIRED**

APA FED ID # 52-1035722

THURSDAY & FRIDAY, NOVEMBER 5-6, 2015
8:00am – 5:00pm

HILTON VIRGINIA BEACH OCEANFRONT

3001 ATLANTIC AVENUE
VIRGINIA BEACH, VA 23451
To make Hotel Reservations:
Call the **1-800-445-8667** or **757-213-3000**

Room rate: \$94.00, SINGLE/DOUBLE, plus taxes (currently 13% tax, PLUS \$1.00 per room per night occupancy tax) SELF PARKING is complimentary. (NOTE: Room rate is based on government per diem rates and may change minimally in October 2015)

All reservations must be guaranteed by a major credit card or advance deposit in the amount of one night's lodging. Reservations not guaranteed will be automatically cancelled at the cut-off date.

CUTOFF DATE for hotel reservations is **10/5/15** Individual departure dates will be reconfirmed upon check-in. (5 DAY CANCELLATION notice required)

REGISTRATION FEE: Pre-paid by October 5, 2015
\$250 APA Member/Applicant
\$250 VPA Member*
\$275 Non-Member

REGISTRATION FEE AFTER October 5, 2015
\$275 APA Member/Applicant
\$275 VPA Member*
\$300 Non-Member

***must be a paid up member of VPA**

AMERICAN POLYGRAPH ASSOCIATION
P O BOX 8037
CHATTANOOGA, TN 37414
1-800-272-8037 or 423-892-3992
Fax 423-894-5435

TOPICS

Thursday: Opening Ceremonies
History of Polygraph (Last 40 years)
Resolving Inconclusive/No Opinion Exams
Criminal Specific vs. Screening Exams
Use of Polygraph in Support of White Collar Crimes - Tim Schroeder

Ask the Expert Panel Roundtable/DPOR

VPA Annual Meeting

Friday: LEPET
Test Data Analysis
Pam Shaw

CONTINUING EDUCATION HOURS

When you attend this seminar, you receive up to 16 CEHs (Continuing Education Hours) approved by the American Polygraph Association and the Federal Certification Program for Continuing Education and Training.

APA Cancellations Refund Policy:

Cancellations received in writing prior to **10/5/15** will receive a full refund. Persons canceling **after 10/5/15 will not** receive a refund but will be provided with the handout material.

Tax Deductions:

All expenses of continuing education (including registration fees, travel, meals and lodging) taken to maintain and improve professional skills are tax-deductible subject to the limitations set forth in the Internal Revenue Code.

(The registration fee includes professional instruction, seminar materials, AM and PM Refreshment Breaks, Continental Breakfast and Lunch)

PLEASE INDICATE IF YOU WILL BE HAVING THE CATERED LUNCH ON THURSDAY AND FRIDAY

THURSDAY ___ YES ___ NO

FRIDAY ___ YES ___ NO

NAME _____ BUSINESS PHONE _____

ADDRESS _____ E-MAIL _____

CITY/STATE _____ ZIP _____

NAME BADGE (CALLED BY) _____

ADDITIONAL \$50.00 FOR WALK-INS

() CHECK MADE PAYABLE TO: AMERICAN POLYGRAPH ASSOCIATION is enclosed
() CHARGE \$ _____ TO MY: VISA () MC () DISCOVER ()

Card number _____ EXP: _____ CV2: _____

Card Holder's name _____ Billing address _____

SIGNATURE _____

CES-Virginia Beach, VA (Nov 5-6, 2015) We can not possibly reach everyone who would be interested in taking part if this seminar. Please help us by making copies of the page for your co-workers and business associates. Thank you for your assistance.

Polygraph Examiner Training Schedule

© Fotolia LLC / kasto

American Polygraph Association

Continuing Education Seminar

November 5-6 2015 (Virginia Beach)
January 28-30, 2016 (New Mexico)

PCSOT Advance Course (Reno, NV)

October 19-21, 2015

Academy for Scientific Investigative Training

Basic Examiner Course

September 21 - November 27, 2015

Basic PCSOT

November 30 - December 4, 2015

Academy of Polygraph Science

PCSOT Course (Fort Myers)

November 9 - 13, 2015

Attention School Directors

If you would like to see your school's course dates listed here, simply send your upcoming course schedule to editor@polygraph.org

Buy and Sell

For Sale: Lafayette LX-4000 with DAS Unit, Pneumos, Cardio and GSR attachments. Also included is a seat activity monitor, software and travel case. Excellent condition! Call Thomas Baum at 757-374-2068 for further information. \$1750.00.



Quality data acquisition begins with your instrumentation
contemporary Lemo® connectors ● medical grade compliance ● custom composite enclosure



The Paragon advantage

High resolution 24 bit data acquisition system.
Nickel plated brass medically approved Lemo connectors.
Lemo push-pull latching technology for a secure connection.
High-Retention USB requires 5 lbs force to disconnect.
Proven EDA technology that works when you need it.

Visit our video library to learn more
www.youtube.com/limestonetechinc

The Silver Solution is everything you need protected in a Pelican instrument case.

- ✓ Data acquisition system: 8 channel DataPac_USB or 9 channel Paragon
- ✓ Polygraph Professional Suite software license
- ✓ 2 pneumatic respiration transducers
- ✓ 1 EDA lead, 1 set of 24k gold plated electrodes, 1 set of snap ends, 1 package of 100 disposable Ag/AgCl wet-gel electrodes
- ✓ 1 adjustable blood pressure cuff, 1 FingerCuff, cardio tubing and Riester sphygmomanometer
- ✓ 1 StingRaySE Piezo electronic CM sensor
- ✓ OSS and Relative Response Magnitude (RRM) scoring algorithms included
- ✓ HARM psychometric pre-employment screening instrument included
- ✓ Printed and bound user manual
- ✓ Pelican 1450 instrument case
- ✓ Lifetime technical support
- ✓ 3 year total care warranty

Discounts available.

Contact us today
for a competitive quote.

All-inclusive polygraph solutions for the professional examiner

Polygraph Professional Suite Silver Solution
Best instrument, best results, best value!



www.limestonetech.com 866.765.9770 sales@limestonetech.com

**AMERICAN POLYGRAPH ASSOCIATION (APA)
CONTINUING EDUCATION SEMINAR
CO-SPONSOR – NEW MEXICO SOCIETY OF FORENSIC POLYGRAPHERS
ADVANCED REGISTRATION IS REQUIRED**

APA FED ID # 52-1035722

THURSDAY - SATURDAY, JANUARY 28 - 30, 2016

Thursday 1:00 pm – 5:00 pm

Friday and Saturday 8:00 am – 5:00 pm

ISLETA RESORT & CASINO

11000 Broadway Blvd SE

Albuquerque, NM

To make Hotel Reservations:

Call the **1-877-747-5382** or **505-848-1999**

Room rate: \$99.00, SINGLE/DOUBLE, plus taxes, be sure to mention **Group Code #NMS01116**

Complimentary WI-FI, valet and self parking and shuttle service to and from the Albuquerque International Airport

All reservations must be guaranteed by a major credit card or advance deposit in the amount of one night's lodging. Reservations not guaranteed will be automatically cancelled at the cut-off date.

CUTOFF DATE for hotel reservations is **12/30/15** Individual departure dates will be reconfirmed upon check-in. (5 DAY CANCELLATION notice required)

REGISTRATION FEE: Pre-paid by December 30, 2015

\$250 APA Member/Applicant

\$250 NMSFP Member*

\$275 Non-Member

REGISTRATION FEE AFTER December 30, 2015

\$275 APA Member/Applicant

\$275 NMSFP Member*

\$300 Non-Member

***must be a paid up member of NMFSP**

AMERICAN POLYGRAPH ASSOCIATION

P O BOX 8037

CHATTANOOGA, TN 37414

1-800-272-8037 or 423-892-3992

Fax 423-894-5435

TOPICS

GREG FOURATT - Cabinet Secretary of NMDPS and Former Federal Prosecutor

Polygraph Laws and Polygraph Cases of importance or interest in reference to admissibility in the NM courts –

MARK HANDLER - APA Editor, AAPP Research & Information Chair

History of ESS w/workshop and practice scoring charts

DLC Questions and DLST Pre-Test Interview practice

Countermeasurers workshop

Photoelectric Plethysmograph workshop

APA Meta-Analytic Review

Instrumentation Workshop

CONTINUING EDUCATION HOURS

When you attend this seminar, you receive up to 20 CEHs (Continuing Education Hours) approved by the American Polygraph Association and the Federal Certification Program for Continuing Education and Training.

.Tax Deductions:

All expenses of continuing education (including registration fees, travel, meals and lodging) taken to maintain and improve professional skills are tax-deductible subject to the limitations set forth in the Internal Revenue Code.

(The registration fee includes professional instruction, seminar materials, AM and PM Refreshment Breaks)

APA Cancellations Refund Policy:

Cancellations received in writing prior to **12/30/15** will receive a full refund. Persons canceling **after 12/30/15 will not** receive a refund but will be provided with the handout material

NAME _____ BUSINESS PHONE _____

ADDRESS _____ E-MAIL _____

CITY/STATE _____ ZIP _____

NAME BADGE (CALLED BY) _____

ADDITIONAL \$50.00 FOR WALK-INS

() CHECK MADE PAYABLE TO: AMERICAN POLYGRAPH ASSOCIATION is enclosed

() CHARGE \$ _____ TO MY: VISA () MC () AE ()

Card number _____ (CVV2) _____ EXP: _____

(CVV2 is a 3 digit number found on the back of your VISA or MC card or a 4 digit number on the front of the AE).

SIGNATURE _____

CES-Albuquerque, NM (Jan 28 -30, 2016) We can not possibly reach everyone who would be interested in taking part if this seminar. Please help us by making copies of the page for your co-workers and business associates. Thank you for your assistance.

IN MEMORIAM PAUL K MINOR 1941-2015

© Fotolia LLC / amboshko



© Fotolia LLC / freshidea

Former Chief Polygraph Examiner for the Federal Bureau of Investigation (FBI), died October 8, 2015 at a care facility in Pennington Gap, VA. The cause was dementia.

Mr. Minor was born in Jonesville, VA and had lived in the Washington area since 1973. He served in the U.S. Army with the Military Police and as a Special Agent of the U.S. Army Criminal Investigation Command before working for the FBI from 1978 to 1987. In 1987, he opened his own private office in Fairfax, VA, and conducted polygraph examinations and background investigations until his illness.

A graveside service was held on Saturday, October 17 at the Minor-Snodgrass Cemetery in Beech Grove, Jonesville, VA.

Published in The Washington Post on Oct. 11, 2015

- See more at: <http://www.legacy.com/obituaries/washingtonpost/obituary.aspx?n=paul-k-minor&pid=176075416#sthash.nhnR8rM0.dpuf>



IN MEMORIAM

LAWRENCE QUICHOCHO

1965 – 2015



Lawrence Quichocho lost his battle with cancer, and passed away peacefully at home with his family by his side on July 23, 2015. He had been battling cancer since 2010.

Lawrence became a member of the APA on June 25, 1995. He served more than 30 years with the Guan Police Department and was posthumously promoted to the rank of Police Captain. While many find an excuse to not go to work, Lawrence would find an excuse to show up every day that he felt strong enough. He took his polygraph testing seriously and was a big influence to those around him. He will be sorely missed.



President's Message

Walt Goodson

When your values are clear to you, making decisions becomes easier.

– Roy E. Disney

Making the APA stronger is my unconditional commitment to you. Where I differ from previous presidents is how I intend to accomplish this task. Past APA leadership focused on making the polygraph exam better and more accepted. Unfortunately, when there is an assessment to use the polygraph, it's more than just polygraph test that's considered. The skill and reputation of the examiner are many times the determining factor in this decision. These factors will continue until the human element is not a part of polygraph testing, and we are a long way from this ever being the case. Therefore, my focus during the following year is to expand opportunities for us to hone our talents and improve our reputation through improved services, influence, and education.

I have argued this philosophical difference between a focus on science vs. a focus on the examiner with a lot of people much smarter than myself and probably lost every argument. Nevertheless, I will continue down this path because the core values of the APA are very clear to me. The values embedded in our mission statement are Integrity, Objectivity, Fairness, and Excellence. These terms epitomize the competent and impartial examiner we all need to be to continue our pursuit of protecting good from evil. Thus, my objectives to honor these values are as follows:

1. Increase the strength and influence of the APA through the growth and retention of APA membership.
2. Raise the stature of APA members by providing opportunities to receive





distinguishing certificates for continuing education, urging college education, and maintaining the effectiveness of the APA school accreditation.

3. Increase the overall efficiency and effectiveness of the APA by refining its business practices and developing comprehensive standard operating procedure manuals.
4. Improve the image of the APA by promoting polygraph as an essential public safety tool that can expand into other venues that protect the public beyond just testing sex offenders.
5. Improve the professionalism of APA membership through a shift from a regulatory mindset to one that recommends and encourages compliance with best practices.
6. Ensure international member compliance with APA Standards of Practice and Code of Ethics by empowering the international membership to self-regulate.

To accomplish these objectives, I have staffed the standing and ad hoc committees as follows:

- Communications and Public Relations Committee – Vice-President Darryl Starks
 - o Sub-Committee – International Membership – Sub-committee Chair – (To be determined)
 - o Sub-Committee – Seminar Interpreters – Director Donnie Dutton
 - o Sub-Committee – Social Media/Communications – Vice-President Darryl Starks



- Ethics and Grievance Committee – Director Steve Duncan (Chair Bill Gillespie)
- Member Services Committee – Director George Baranowski
- Professional Development Committee – Director Barry Cushman
- Research and Development Committee – Chairman of the Board Raymond Nelson
- Education Accreditation Committee – Director Jamie McCloughan and VP Dan Violette
- Standards and Specialized Testing Committee – President-Elect Patrick O’Burke
- Post-Conviction Sex Offender Testing Committee – Chairman Ray Nelson & President-Elect Patrick O’Burke
- Ad hoc Committee - Strategic Plan - Director Donnie Dutton
- Ad hoc Committee - Awards - Director Donnie Dutton
- Ad hoc Committee - Advanced Training - Chairman of the Board Raymond Nelson

Quarterly committee reports will be published in our bi-monthly magazine to provide you with a clear picture of the goals, work and accomplishments of each of these working groups during the upcoming year. We are also exploring opportunities to use social media and the web to create a dialog between the membership and these committees. Such communication seems like the most efficient way for members to share their thoughts, concerns and expertise with these committees.

As a final note, it was a genuine pleasure to work with Past-President Chuck Slupski and Past-Director Bill Fleisher on the APA Board. These men contributed significantly to the APA during their tenure on the Board as well as throughout their careers. I will miss their experience, integrity, and kindness.

We as your Board of Directors look forward to pushing the APA forward during our next year of service to you. As always, thank you for your dedicated service to your communities and the professionalism in which you approach these indispensable duties every single day. It’s a great joy to be a part of the professionals that comprise this organization.



Board of Directors' Reports

Patrick O'Burke
President Elect

September 2015 APA Journal

The fiftieth annual American Polygraph Association conference is now in the history books. I thoroughly enjoyed this visit to Chicago, a city that is rich in polygraph history. Chairman Mike Gougler, along with many others, put on an outstanding conference with one of the highest attendance numbers on record. Several of the APA members from the first conference fifty years ago were in attendance. I want to thank them for the legacy they have left us, as well as sharing their memories at the banquet. F. Lee Bailey was also present as guest speaker and I found that to be a special treat as well. The topics from the seminar were informative and interesting and I wish I could have seen them all.

The membership also voted in Chicago to adopt the new APA By Laws that had been prepared by the Board. These new By Laws were drafted from the old APA Constitution after a corporate legal review by an outside law firm recommended the change. Essentially, the Constitution is

now the new updated APA By Laws. The Standards of Practice are updated as well, with many language revisions and moving some old standards into Best Practices or Model Policies. By the time you read this we hope that all of the new documents are posted on the new APA website.

I sure hope that you are going to the new APA website. If not, please get signed up with an email address and a login as soon as possible. The APA website is your source for receiving information, paying for membership, sharing with other professionals and registering for our conferences. The APA website is now the premier location on the World Wide Web for obtaining public interest information and research documents regarding polygraph. If you did not know, going to websites that are adverse to our industry moves those negative websites further up in Internet search engines. Do our industry a favor, share with anyone who is interested that the APA website is their polygraph information resource and that they should avoid those websites that portray our industry in a negative light. The redrafting of the By Laws also gave the Board an excellent opportunity



to strengthen our relationships with international polygraph associations. A new membership status was created in the new By Laws for Divisional Affiliates. This was an effort to allow a Not for Profit polygraph association to have a formal partnership with the APA in supporting professional and evidence based polygraph. We are hopeful that these shared partnerships will facilitate compliance with best practices and ethical standards worldwide. The development of the application process is ongoing and should be completed shortly.

Sharing responsibility among polygraph associations across the globe seems to be a partial solution for the complex problems associated with ensuring that examiners are trained and in compliance with the high standards for best practices set out by the APA. The language below is a portion of the requirements that were adopted for any associations that have an interest.

- *Divisional Affiliates are only those not for profit polygraph professional membership organizations or associations who desire a professional relationship with the APA and whose members agree to abide by the APA Code of Ethics and the APA Standards of Practice. No individual may claim APA membership as a result of being*

a member of a Divisional Affiliate. An applicant for Divisional Affiliate shall:

—Deliver a copy of its then current bylaws (or the equivalent thereto) to the APA and, if granted membership by the APA, immediately provide the APA with subsequent revised versions of such bylaws; and

—Be granted Divisional Affiliate status upon at least a two-thirds (2/3) vote of the Board of Directors at which a quorum is present.

I was able to meet with numerous international members in Chicago as part of our efforts to develop Divisional Affiliate memberships. There appears to be a very strong interest so far in this concept. The process is currently in development and I hope to see it finished by the time this is published. If you represent a polygraph association with an interest then please get in contact with me.

Walt Goodson, our new President, laid out a very strong Strategic Plan for the APA over the next few years for the new Board in Chicago. Walt's vision was also discussed at the banquet in Chicago and in person with many members. I hope



you take the time to look over his plans or visit with Walt. It is our goal as a Board to be responsive to your needs and one that you are proud of. Please look over Walt's message in the magazine.

Thanks and I hope to see you at a conference soon.

J. Patrick OBurke

George H. Baranowski
Director

I won't be surprised if other reports from Board Members start out with this comment, "Wow, what a conference." I think it was truly was the most remarkable conference in the history of the American Polygraph Association. Speakers were brilliant and subjects presented were excellent. I don't have the final attendance figures, but I have been told that this is the largest attendance we've ever had. The Palmer House speaks for itself. I was quite taken by the conference reception party that was held. In my 30 years of attending such conferences, this was by far the most extraordinary APA Welcome Reception Party I have ever attended in appearance, food, service, atmosphere and hospitality. The crowd was huge. This again spoke of the proficiency of the Palmer House as well as our Seminar Chairman Mike Gougler in planning this

event. Speaking of Mr. Gougler, there were numerous platitudes voiced toward Mike, President Raymond Nelson as well as other Executive Board members during the conference regarding the professionalism as well as the efficiency of the conference. It was no surprise to hear the countless positive comments directed toward our National Office Manager Lisa Jacocks and her staff in the way they were able to manage and provide assistance to the huge attendance present.

There was also some great after hour's conference activities provided such as the Cubs ballgame at Wrigley Field (The cubs lost, but that happens). However, the Mystic Blue Cruise and Dinner event on Tuesday night was fantastic. It sounded great when it was discussed at our prior board meetings but it surpassed my expectations. (Oh by the way, did I tell you it included an open bar furnished by Complete Equity Markets). It was a great event.

The APA Annual Business Meeting provided some significant information regarding some positive changes in our bylaws and progressive changes regarding the design and information in our new APA Website, thanks to the expertise of Editor Mark Handler.

There were a number of celebrity speakers



at this year's conference that included F. Lee Baily, David Raskin, Charles Honts, Lynn Marcy, Don Krapohl, and Frank Horvath.

The APA Annual Banquet and Awards event is always outstanding and this year was no exception. One of the wonderful surprises I personally encountered was meeting and talking with so many of our foreign members. I personally had not talked to any members from Russia or Poland during conferences before. I know my wife Paula got to know some members from South Africa.

I want to also mention that I will continue to chair the Membership Services Committee during this next term, and I want to share some positive benefits that our committee is working on that I feel will be great. The goal is directed to build membership and present advantages to our present members that we have not explored before. These will include financial discount benefits to members desiring multiple year membership; discounts for initial group enrollment; advantages offered to new members, recognition of member's years of membership in the APA, and other surprises to be announced.

Getting back to this year's conference, I of course look forward to next year's

conference and all this provides a good amount of expectation towards the 2016 APA Conference that will be held in Baltimore. But I think it goes without saying that this 50th Anniversary Conference that was held at the remarkable Palmer House in Chicago will be talked about with accolades for many years to come.

Positive Procrastination

Yes, you read that right. At a speech I gave at a 1992 Conference in Nashua, New Hampshire, I introduced this term "Positive Procrastination." The talk was about being a positive person. Yes, it did receive a few chuckles and some later comments that surprised me because I was sure there would be a lot of opposition to this kind of thinking. I was pleased at the remarks made, because the points delivered apparently made an impression. By the way, I don't really believe positive procrastination to be just a tongue in cheek comment. There's real value in this concept.

Most businessmen and professionals alike believe the old adage "Don't put off until tomorrow what you can do today." That may not always be the best advice for all situations and decisions. There are compelling reasons for thinking just the opposite. Put off ever major decision as



long as you can. I'll qualify this later. Executive problem solving, decision making, important judgements – should be a creative process. We need new creative ways to handle people, our business, technology, our budgets, expenses and even the marketing of our services if you're a private examiner. The concept of a successful enterprise, any profession, any association or the running of any management system is based on the theory that there will be a constant flow of new ideas...and new ideas often include change...and new ideas need time! Time is the key.

All the boastful statements about winners belong to the swift and the bold, ignores many of the points to be made on behalf of POSTIVE PROCRASTINATION, or put another way, THE CREATIVE USE OF INDECISION. (Oh there you go laughing again.)

I started to think about this during Executive Board Meetings of the American Polygraph Association I have attend the past few years. I was thinking about the many decisions and revisions that continue to change each year, and always with benefit. I began to think that this kind of premeditated procrastination gives us the gift of time, time to think, to reflect, to take measure, the see all aspects of issues, and if you will, to appreciate the

scope of each problem and speculate alternative solutions. It's no surprise to any of us that people in a hurry, people with a compulsion to act, to exercise quick judgement are often individuals so occupied with mundane matters that they unfortunately miss the opportunity to hesitate or contemplate on things that are really important.

By withholding decision making in order to explore all of the alternatives, or as many as time will possibly allow, we avoid the trap of giving in to the tendency to take the first choice that occurs, to make a snap finger or knee-jerk decision. Quickest is not necessarily best. I wish I could remember how to pronounce an old Latin phrase that I learned in school but I remember it meant "Hasten Slowly." I was knocked out by that phrase and I admit that I haven't always been able to convince my wife Paula that I was hastening slowly, but it's still a great term.

Now at the same time, recognizing that there are times when decisions must be made quickly, and recognizing that procrastination can be carried to the absurd or undesirable extremes, there is still a case to be made for positive procrastinating in many, if not most, even urgent situations.



It's not necessarily true that he who hesitates is lost. He may be a winner. A case can be made for INACTIVITY. People in a crisis feel a need to ACT. Maybe it helps them psychologically, but it rarely helps their case. Instead: when in difficulty, remain inactive. When you find yourself at a crossroad, don't just automatically take one of those roads without some contemplation.

In each of our private lives – and our work environment – the problems that come before us are often quite diverse. Only rarely are they of the “house-is-on-fire” urgency. More often, they are problems that don't have to have immediate, and too often, knee-jerk solutions. On the contrary, they are problems to which there are many alternative approaches, one of which may be to do nothing for the time being.

One thing that is good about delaying a decision; the problem may solve itself. It may go away. And even if it doesn't the process of positive procrastination will usually result in a far superior decision than hasty action.

But there is something that has developed in our makeup that causes us to put the person with a reputation for making quick, snap-of-the-finger

decisions on a pedestal, and as a result, lowering the procrastinator to a lesser level of esteem. Maybe its role-playing. Maybe all of us like to relate to movie or television heroes. The Indiana Jones type character for example, a person in action roles, faced with constant judgement calls requiring on-the-spot decisions.

But there you're back to the house is on fire example, and 99 percent of the problems that come before us in our job, our workplace, our home... wherever...It's just not that way. These problems are ones that legitimately lend themselves to a more deliberate and consideration process, one that explores the immediately apparent alternatives and seeks to uncover many additional ones.

Decision making is a problem solving process. At its best it is a stimulating exercise in creative thinking and often leads to the best possible solution that can be found in the maximum amount of time available. Yes, what I'm saying is that this means the decision should be put off as long as possible....**BUT WITH TWO PROVISIONS:** One: that the period of indecision doesn't hurt anyone, and two, that the time gained is used to create and consider alternatives.

I want to share a quick comment I made



about this kind of thing to Mike Gougler a couple of years ago that dealt with the idea of looking at alternatives. I told Mike that Thomas Edison is said to have tried over 2500 different combinations before he found the correct filament for the incandescent light bulb. I remarked to Mike, “What if he had stopped at say 1500 and said that was it. Would it have done as well...or would it have worked at all? He made some remark about if Edison was Polish or something like that and said he didn’t know, and then I added, “If that happened, gosh we would all probably be watching television by candlelight.”

Here’s another point, you know when someone gives us a large ring of keys to fit a particular lock on a door and you don’t open it after stopping at key number 15, you never know if key number 16 might have opened the door. So we need to continue to look for alternatives. The only thing that seems to govern the number of alternatives is TIME.

Positive procrastination in our decision-making process means that we have the advantage of incorporating into our ultimate action what would have been hindsight and second thoughts had we acted hastily and made snap judgements. Take time scoring those charts. Look closely at every detail, every statement

made to you in the pre-test interview. Positive procrastinating time, creatively used, is never wasted time.

Gary F. Davis **VP Private**

The 50th Annual Seminar is now behind us. I would like to thank those who voted in the Election for supporting my candidacy for Vice President - Private and the other Board Members. Having been on the job for less than two months, I want to assure the membership I will work hard every day to promote the goals and objectives of the APA.

If you missed the training in Chicago, you really missed an outstanding group of speakers. In 1982 when I graduated from the Polygraph Program at the University of Houston, I thought I knew a lot. However as time progressed, I learned every day was a training day. Over the years the Polygraph Profession has matured and grown. One of the biggest leaps was the adoption of Evidence-based Testing. Those of us following the use of Forensic evidence in Courts, recognize tests and procedures based on Scientific Research and procedures are the keys to quality outcomes and reduction in malpractice litigation.

Speakers at the Seminar included



Academia, Scientific Researchers and Practicing Examiners. Each brought a different prospective to polygraph testing. The common thread was Evidence Based Testing using Validated Techniques and Scoring Models is the future of Polygraph. As a profession we must grow into the Research Based testing and learn from the Scientific Community.

During the Seminar I had the opportunity to visit with a number of examiners from around the world. I was surprised by indifference in embracing the changes we face. Foreign examiners seem to actively embrace the changes while many of American Examiners were reluctant to accept some if not all of the changes. The common thread was “this is what I was taught” and it works for me.

I was really surprised by the number of examiners using analog instruments. Granted all were “long time” examiners who expressed the opinion “if ain’t broke, don’t fix it”. I submit it is broken. Back in the “day” analog instruments were all we had. Today, we have options, with least four major manufacturers with various software packages examiners can choose the system that meets their needs.

Computers offer the ability to improve the reliability of a test outcome. If there is one thing a computer does really well

is measure the data gathered during the examination. Using computers allows precise measurement of reaction size and duration. Validated algorithms can predict the probability that a subject falls in normative data groups for truthful and deceptive subjects. Computers along with audio and video recording allow examiners to review their work, identify problems occurring during data collection and any contamination that might occur during the pre test interview. What computers cannot do, is tell the difference between a distortion and a reaction that is the responsibility of the examiner. Much work has been done and remains to be done in the scientific detection of deception. The APA is the leader in these endeavors and deserves our support.

During the up coming year, I have been assigned to work with President Elect O’Burke on PCSOT and Professional Development. I pledge to do everything possible to spread the “good news” and benefits of Evidence-based Testing, Validated Testing Techniques and Scoring. Should any member have concerns or comments I can be reached by email vp-private@polygraph.org or use my toll-free number, 866-535-8969.



Steven Duncan
Director

Fellow APA Members, I trust everyone made it home safely from the phenomenal Seminar in Chicago this year. It was a great Seminar for those of you who couldn't make it. My hat is off to the people, too numerous to mention, who made it a success.

I want to take this opportunity to thank the membership for your support in electing me to the Board. I will work for you and represent you to the best of my abilities to advance Polygraph and the Association.

As a Board, we had a productive Meeting after the Seminar with our newly elected President, Walt Goodson, setting goals and expecting the same hard work he is known for. Having been appointed to direct the Ethics and Grievance Committee, I am working on setting up the Committee and intend to complete a Policy which was already in the works for direction. My plans also include working with others on a couple of projects and assisting other Board Members whenever requested.

If I can assist any Member, feel free to call or email me.



©FotoliaLLC/gustavofraza



American Polygraph Association

Antitrust Compliance Program

Introduction

The American Polygraph Association (APA) is a not for profit membership corporation incorporated under the laws of the District of Columbia. It has approximately 3,000 members. The majority of the members are polygraph examiners, and fall in the categories of full members or associate members. Persons who have demonstrated professional or scientific interest in promotion and advancement of the polygraph profession through polygraph research or instrumentation may join as Science and Technology affiliates. A full member must be a graduate of a polygraph education program that substantially meets APA accreditation standards at the time the member graduates; must have completed at least two hundred polygraph exams using validated polygraph techniques as taught by APA accredited programs; and must have a baccalaureate degree. Associate members must be graduates of a polygraph education program that substantially meets APA accreditation standards at the time that the member graduates. Associate members may upgrade to full membership upon completing certain requirements relating to education and or experience.

All APA full members and associate members must conduct their practices in full conformance with the APA Standards of Practice and Code of Ethics.

APA members include polygraph examiners practicing in the United States and in many foreign countries. APA accredits polygraph education programs both in the United States and in foreign countries.¹ APA has Division affiliates which are organizations that agree to comply with certain APA Standards of Practice and Ethics requirements.

Antitrust Exposure for Associations and Association Members

The basic U.S. antitrust law (the Sherman Antitrust Act) is a conspiracy statute that prohibits two or more entities from engaging in conduct that unreasonably restrains trade.

¹ If APA conducts business in foreign countries, it may be subject to the antitrust laws of each country in which it does business.



In general terms, the Sherman Act prohibits competitors, directly or indirectly, from entering into agreements to fix prices, rig bids, allocate customers or territories or boycotting or refusing to deal with vendors or competitors. These types of violations are what are known as “*per se*” violations. That means that if a group of competitors are found to engage in one or more of these practices, the Court will not consider any excuses.

A “*per se*” violation of the Sherman Act subjects the violators to civil and criminal suits by the Department of Justice, civil and sometimes criminal suits by State Attorney Generals and treble damage suits by private plaintiffs. Individuals convicted of “*per se*” criminal violations of the Sherman Act are guilty of a felony and face mandatory jail sentences of up to 10 years.

All individuals, corporations, or other entities that violate the antitrust laws are also subject to civil penalties and private litigation that may result in treble damage awards.

Trade and professional associations may provide a forum for antitrust violations. At trade and professional association meetings, groups of competitors gather and unless an antitrust compliance program exists, the discussion may involve pricing. Such discussions can lead to direct or indirect agreements on what is a “fair” price or what is a “minimum” price to charge customers. If such an agreement is reached at a trade or professional association meeting, the individuals involved, the companies represented by those individuals, the trade or professional association and the trade or professional association staff attending the meeting could all be found to have committed a “*per se*” violation of the Sherman Act and be subject to the criminal penalties, including jail, provided by the Act.

In addition to “*per se*” type violations, the Sherman Act also prohibits conduct that involves a less serious type of violation that is generally described as an “unreasonable” restraint on trade that does not fall in the “*per se*” category. Cases brought against trade and professional associations under this theory are civil cases which involve monetary damages and possible injunctive relief. These cases involve allegations such as unreasonable membership restrictions



by an association or utilization of an association certification or standards program to “unreasonably restrain trade.”

“*Per se*” and “unreasonable restraint of trade” cases are usually prosecuted by the Antitrust Division of the Department of Justice. The Antitrust Division is the only federal antitrust agency with criminal enforcement authority. However, there is a second federal antitrust agency, the Federal Trade Commission (FTC) that has a broader range of enforcement authority than the Department of Justice.

Section 5 of the FTC Act declares that all unfair methods of competition or unfair or deceptive acts or practices affecting interstate commerce are illegal. However, the statute does not define what is an “unfair method of competition” or an unfair or deceptive act or practice.”

In recent years, the FTC has used Section 5 of the Federal Trade Commission Act as a basis for attacking trade and professional association codes of ethics that restrict the right of members to advertise; trade and professional association codes of ethics that declare it is “unethical” for a member to solicit another member’s customers; and trade and professional association codes of ethics that restricts a member from offering another member’s customer a discount to switch vendor’s.

The FTC has also attacked association minimum fee schedules and actions by associations to induce state legislatures to prohibit second level professionals from performing certain services previously restricted to first level professionals. In most cases, FTC actions result in Cease and Desist Orders against the associations. However, in certain cases, the FTC has the authority to seek civil penalties and disgorgement of illegally obtained profits.

Both the Antitrust Division of the Department of Justice and the Federal Trade Commission have repeatedly emphasized that trade associations, professional associations, and corporations need to establish a culture of antitrust compliance by establishing comprehensive antitrust compliance programs specifically directed at the type of antitrust risks to which the organization has the most exposure.



To establish a culture of antitrust compliance, the association should adopt a custom-designed antitrust compliance program, implement the program in a meaningful manner, communicate the details of the program to officers, directors, members and staff, set up a schedule for re-education updates and establish a “whistle-blower” program to encourage members and staff to report possible antitrust violations without fear of reprisals or loss of employment.

It is with this background, that the American Polygraph Association has established its antitrust compliance program.

How the Antitrust Laws Apply to APA and Its Members

I. Description of APA

APA is a professional association of polygraph examiners and organizations, corporations and persons who have a professional or scientific interest in polygraph research, instrumentation and the profession.

APA establishes standards of practice and ethical standards and accredits polygraph training institutions. APA regularly holds educational meetings for members and supports polygraph research and training activities and publishes a peer reviewed journal. In its “Mission Statement,” APA states that one of its goals is: “Governing the conduct of members of the Association by requiring adherence to a Code of Ethics and a set of Standards and Principles of Practice.”

Some polygraph examiners work for their own companies. Some polygraph examiners work for larger organizations that provide polygraph services to the public, corporations and the government. Some polygraph examiners work for government agencies.

II. Competition

Organizations and individuals providing polygraph services to the public sector and to government agencies are direct competitors. Polygraph examiners who act to “govern the conduct” of other polygraph examiners are engaged in antitrust sensitive conduct in that they collectively may restrict what other competitors can do. There are certain types of conduct by an



association and its members that are so egregious from an antitrust perspective that they are considered to be illegal “*per se*.” This means that if it can be proved that the association and its members engaged in this type of conduct, there are no defenses or excuses. Individuals found guilty of *per se* violations can be found to be subject to criminal penalties, including jail..

There are other types of antitrust conduct that are considered less serious. These types of conduct are covered by the antitrust “rule of reason.” Under the “rule of reason,” a court will find that this type of conduct violates the antitrust laws when it can be shown that the association and its members have the power to affect prices in a given market and where the anti-competitive effects of the conduct in question outweigh the pro-competitive benefits.

The following examines both categories of conduct with specific reference to the conduct of APA and its members.

III. “*Per Se*” Antitrust Violations

A. Price Fixing

An agreement by a group of professionals to fix the price that they charge for their services is a “*per se*” violation of the antitrust laws. In this context any agreement that “affects” prices will be considered the same as an agreement to “fix” prices.

As competing professionals, polygraph examiners may not agree on:

- 1) amounts to charge for various types of polygraph exams;
- 2) An amount of surcharge to add to the base amount for additional services;
- 3) What services are to be included in a base charge and what services should be subject to an extra charge;
- 4) What is a “fair” minimum charge for a polygraph exam?
- 5) Whether to charge for missed appointments;
- 6) Whether or not to charge interest for late payments or when to start charging interest or the amount of interest to charge;
- 7) Whether to include one certified copy of the final report in the base price or whether to charge for additional copies; and
- 8) Any other matter that affects the price of the services offered.



B. Customer Allocation

It would be illegal and a *per se* anti-trust violation for a group of polygraph examiners to agree to allocate, assign or divide customers. As an example, they could not agree that all requests for service from Customer A will go to Examiner X and all requests for service from Company B will go to Examiner Y. Customer allocation agreements take various forms including:

- 1) Agreements not to solicit certain accounts;
- 2) Agreements to quote “high prices” to non-favored accounts;
- 3) Agreements to provide poor service to accounts coming from a co-conspirator; or
- 4) Agreements to divide an account.

C. Territorial Allocation

Group of competitors cannot agree to limit offering services to specific geographic areas.

1) It would be illegal and a *per-se* anti-trust violation for several polygraph examiners, all of whom are licensed to provide services in a certain state, which has five major cities, each to agree to provide services in one of the five cities and not to provide services in the other four.

Similarly, it would be illegal for two firms of polygraph examiners located in the same city to agree that one firm will provide services only to customers located on the east side of the city and that the other firm will only provide services to customers located on the west side of the city.

D. Bid Rigging

It would be illegal and a *per se* anti-trust violation for two or more polygraph examiners to enter into an agreement to affect or rig a bid for services. This would include:

- 1) Agreeing that if four jobs are up for bid, Examiner A will bid low on Job X and other examiners will bid high;
- 2) Agreeing to alternate bidding high and low to ensure that all get a “fair” market share;
- 3) Refusing to bid on certain jobs to protect the “favored” bidder;



- 4) Agreeing to submit an intentionally high bid to make sure that a bid from a friendly competitor is accepted; or
- 5) Engaging in any other bidding conduct designed to make sure that a favored bidder is successful.

E. Boycotts or Refusals to Deal

It would be illegal and a *per se* anti-trust violation for two or more polygraph examiners to agree to refuse to deal with a competitor or vendor offering a legitimate product or service to the market. As examples:

- 1) Vendor A and Vendor B make competitive models of polygraph machines. Independent tests show that Vendor A's machines are better than Vendor B's machine. APA could publish the test results but could not recommend that all members buy only brand "A." APA could publish the test results and recommend that members consider the test results when making equipment purchases.

- 2) Certain states license polygraph examiners. APA may require that regular members operating in states with licensing requirements not only meet state licensing requirements, but also meet additional and more stringent membership requirements. APA could not require that members in a state with licensure requirements limit referrals only to other APA members in that state.

The antitrust statutes are conspiracy statutes prohibiting agreements among competitors to engage in the practices set out above. Acting unilaterally and not pursuant to any agreement, an individual polygraph examiner can set whatever prices, deal or refuse to deal with any customer or bid or not bid on any job, based on his or her own economic objectives.

F. Association *Per Se* Liability

If association members engage in conduct that is "*per se*" illegal while attending an association meeting and the association, directly or indirectly, has knowledge of such illegal activity, the association and the association staff who participate in the illegal conduct, directly or indirectly, may be held to be co-conspirators and equally liable.



As an example, if the members of the association decided to establish minimum fee levels at an association Board meeting and an association staff member sat through the entire meeting, took minutes, including the details of the minimum fee agreement, the association and the staff members could be found guilty of a criminal antitrust violation and the staff member would face criminal penalties including a jail sentence of not less than one year or more than ten years for engaging in a conspiracy to fix prices.

IV. Rule of Reason Antitrust Conspiracies

As a professional association, APA provides benefits for members that enable them to compete more effectively. APA requires that members meet certain standards and comply with Standards of Practice and a Code of Ethics. APA establishes standards that educational institutions with programs in polygraph education must meet to be accredited by APA.

Since not every polygraph examiner, even if licensed in the state in which he or she practices will meet APA membership criteria and since not every school that offers a program in polygraph education will qualify for APA accreditation, potential antitrust issue arises.

If APA's membership criteria do limit the ability of state licensed polygraph examiners who do not meet APA's membership criteria to compete in the marketplace, then there is conduct that, on its face, may be considered a concerted action by a group of competitors that restrains trade.

The conduct in question does not fall in the *per se* category and, as such, will be evaluated under the antitrust "rule of reason." Under the "rule of reason" the question is "Does the association have the power to affect a defined market?" If so, do the anti-competitive effects of the conduct outweigh the pro-competitive benefits? If the anti-competitive benefits do outweigh the pro-competitive benefits we have an unreasonable restraint on trade that arguably violates the antitrust laws.

For purposes of anti-trust consideration, a person claiming an anti-trust violation may argue that APA membership has economic value and that non-members may face impediments to employment in certain markets.² However, as a professional organization APA is entitled to

² Although United States District Court for the District of Arizona, in the case of *Haswood et al. v. American Polygraph Association, et al.* (Civ. 14-00253 PHX-GMS) implied that with regard to accreditation of schools APA does not have market power, it never actually ruled on that issue as it dismissed the case on procedural grounds including lack of standing as to certain plaintiffs and failure to allege antitrust injury as to the remaining plaintiffs.



set reasonable membership criteria. Also, although certain states may require some form of APA membership for licensure, such action is state action, not APA action.

APA's requirements for membership must be established based on specific criteria that the association believes are important to establish a skill level necessary for a highly qualified polygraph examiner.

As a professional organization, APA can adopt membership criteria that require a high level of skill sets rather than a minimum level of skill sets as long as the purpose of the practice is not to restrict access to the profession.

Membership in APA is open at various levels and the requirements for membership are designed to encourage high levels of professional conduct for the benefit of the public. Polygraph examiners who do not meet APA's requirements for membership are free to practice their profession subject to any state licensing requirements and APA does not engage in conduct aimed at denying non-members from access to the market.

APA's membership restrictions have pro-competitive benefits that outweigh the anti-competitive risks and thus strongly argue for meeting the test of the "rule of reason."

Where professional organizations establish education standards for education and training to be used by schools which train polygraph examiners, such standards, in order to meet the "rule of reason" should be reasonably designed to promote a level of educational achievement that will produce graduates who have skill sets necessary to achieve an appropriate level of professional competence. The level of professional competence need not be a minimum level but can be a higher level as long as APA has a rationale and reasonable substantiation for believing that the level of professional competence results in properly qualified graduates. If APA can show that its accreditation standards can be substantiated on a rational and reasonable basis and are not designed to keep qualified educational programs out of the market, APA's conduct should meet the requirements of the rule of reason.

APA's accreditation standards are developed by the School Accreditation Committee and approved by the APA Board of Directors. All the components of the standards are carefully reviewed during the developmental process and the final document reflects the opinion of the Committee and the Board as to what standards are necessary for a school polygraph educational program. The standards are designed to protect the public by accrediting educational programs that will produce highly qualified polygraph examiners. Accreditation by APA is voluntary. A



full or associate member of APA need not have graduated from an APA accredited educational institution but rather one that meets the accreditation requirements at the time of graduation.

APA does not advocate that polygraph examiners who have not graduated from an APA accredited educational program be denied access to the market.

It therefore appears that the APA accreditation practices meet the requirements of the “rule of reason.”

V. Adoption of Antitrust Compliance Program

In order to ensure that APA and its members do not engage in practices that may violate the antitrust laws, APA has, by vote of the Board of Directors, adopted this Antitrust Compliance Program. As part of this program APA will follow the following practices.

(A) *At Association Meetings:*

- (1) *Do not* discuss current or future prices (be very careful of discussions of past prices).
- (2) *Do not* discuss what is a fair profit level.
- (3) *Do not* discuss an increase or decrease in price.
- (4) *Do not* discuss standardizing or stabilizing prices.
- (5) *Do not* discuss pricing procedures.
- (6) *Do not* discuss cash discounts.
- (7) *Do not* discuss credit terms.
- (8) *Do not* discuss surcharges such as additional charts for copies of reports.
- (9) *Do not* discuss controlling sales.
- (10) *Do not* discuss allocating markets.
- (11) *Do not* complain to a competitor that its prices constitute unfair trade practices.
- (12) *Do not* discuss refusing to deal with a competitor because of its pricing or distribution practices.
- (13) *Do not* attend “rump” (informal meeting) sessions in connection with association meetings.



(B) *As to Self-Regulation and Membership Policies:*

- (1) *Avoid* restrictions on dealing with nonmembers.
- (2) *Avoid* unreasonable exclusions from membership, especially if there is a business advantage in being a member.
- (3) *Avoid* limitations on access to association information and publications, unless the limitation is based on protection of trade secrets or failure to provide data to an information exchange program.³

(C) *As to Ethical Codes:*

- (1) *Do not* require other members to refuse to deal with any member violating the association's code of ethics.
- (2) *Do not* arbitrarily enforce the code.
- (3) *Do not* impose unreasonably severe penalties for violations of the code.
- (4) *Do not* promulgate or enforce regulations or policies which have price-fixing implications, such as preventing the advertising of prices.

(D) *Antitrust Compliance Education*

As part of APA's Antitrust Compliance Program:

- (1) APA's Antitrust Compliance documents will be published on the APA website and all members will be encouraged to review the documents.
- (2) APA will have an annual antitrust compliance education session as part of a Board meeting.
- (3) APA will have an annual Antitrust Compliance Education session for APA staff.
- (4) APA will send a copy of its Antitrust Compliance Program to all Divisions and obtain their agreement to comply with the program.
- (5) APA has adopted an Antitrust Whistleblower Policy and will provide all staff members with a copy of the APA Antitrust Whistleblower Policy (attached as Exhibit A).

³ Non-members can be charged a fee that is greater than the fee charged members for purchasing publications or attending educational program. The fee differential must reflect the cost incurred by members in developing and production of the publications or program.



(6) APA will read the Antitrust Compliance Statement (attached as Exhibit B) before all Board meetings and membership meetings.

VI. Antitrust Investigations

A. Allegations Regarding Antitrust Violations

In the event that any allegations of possible antitrust violations are reported to APA's staff or APA's volunteer leadership, legal counsel will be contacted immediately. Legal counsel will make a thorough investigation of the allegations and report the results of the investigation to the APA Board of Directors with a recommendation for appropriate action.

B. Federal Trade Commission (FTC) or Antitrust Division, Department of Justice (DOJ) Investigations

1) Written Inquiry or Subpoena

In the event that the association receives a written inquiry or subpoena from a federal or state antitrust agency, the inquiry or subpoena will be immediately sent to legal counsel for review.

2) Visit by FTC or DOJ Investigator

An APA staff member shall be appointed as the responsible person to meet with any FTC or DOJ investigator who visits the association offices without warning and requests access to books and records of the association or requests to interview employees.

If such a visit occurs, the responsible staff person should obtain the name of the investigator, his or her contact information and ask to look at the person's identification.

The staff person should ask the investigator to explain the purpose of the investigation and then politely state that it is the policy of the association to cooperate with all government investigations but before answering any questions or providing access to any files or documents, the staff person must consult counsel.

The investigator should be asked to wait in the office reception area while staff person calls counsel and receives advice on how to proceed.

In the event that the investigator has a subpoena, the staff person should get a copy of the subpoena and send an electronic copy to counsel immediately. In very rare occasions, the Department of Justice will obtain a court warrant to conduct a raid on the offices of a company



or an association. In such a situation several FBI agents will show up at the associations offices, ask all the employees to go to one location and begin seizing documents, computer files, computers, etc. Employees will not be permitted to call counsel, use the telephone or use cell phones until the raid is completed. It is extremely unlikely that such a raid would occur at APA. The FBI needs a warrant issued by a court to authorize such a raid. A subpoena does not provide authority to obtain immediate access without first giving the association the right to contact counsel and obtain counsel's advice on how to proceed. Staff should be educated as to how to respond to an antitrust investigation.

VII. Minutes and Agendas

A detailed agenda should be prepared prior to all meetings of the association and the association's Board of Directors. Counsel should review the agenda to ensure that there are no antitrust sensitive issues scheduled for discussion. If counsel determines that a scheduled discussion item may be antitrust sensitive, counsel will advise the association of the best way to deal with the issue presented.

Accurate minutes should be kept of all association and association Board of Directors meetings. Minutes should be approved by counsel before adoption.

VIII. Rump Sessions

The APA will not permit rump sessions to be held in connection with association meetings.

Approved by the APA Board of Directors on _____.
(date)



Exhibit A

APA Whistleblower Policy

It is the policy of APA to fully comply with all laws including federal and state antitrust laws. Compliance with the law means not only following the law but also creates an obligation on all APA employees to report to his or her supervisor or to APA Counsel, any activity of the association or association members that the employee has reason to believe may violate any law including the antitrust laws.

It is recognized that all employees are not legal experts. Employees are encouraged to seek guidance from supervisors or legal counsel whenever the employee has a legal compliance question.

In no instance will any employee be sanctioned or adversely affected from bringing any such matter to the attention of his or her supervisor, the association or the association's legal counsel even if it turns out that no violation of law or policies exist.

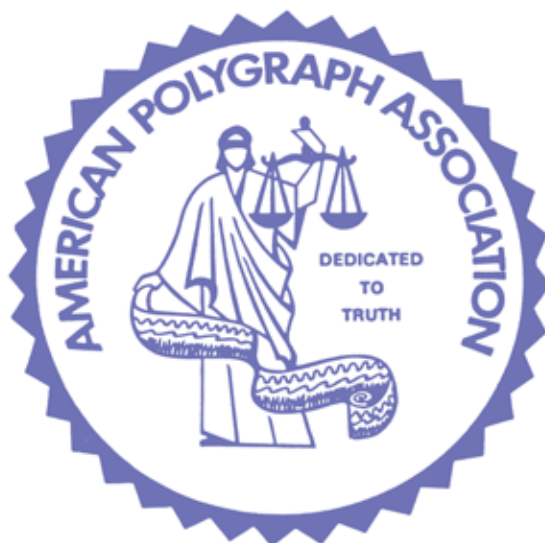

Exhibit B

APA Antitrust Policy Statement (To Be Read Before All Association Meetings)

It is the policy and intent of the American Polygraph Association (hereinafter APA), its Officers and Members to comply with all federal and state anti-trust laws, regulations and amendments thereof. APA has adopted a comprehensive Antitrust Compliance Program which is available on our website. APA recommends that all of you become familiar with the program.

The APA shall not, nor shall any of its Officers or Members, in any fashion whatsoever attempt to lessen competition or fix prices or to create a combination or monopoly in violation of federal or state laws.

Discussions of price fixing and/or price levels are strictly prohibited. There shall be no discussion as to the allowances for discounts, terms of sale, profit percentages and/or mark ups.

Discussions of a division, separation and/or limitation of territories, customers, and/or service providers and/or limitation of the nature of business carried on or products sold and/or services delivered are not permitted.

Boycotts in any form or nature are strictly prohibited. Discussion or engagement relating to boycotts, blacklisting, unfavorable reports about a particular individual, company or organization, including their financial situation is strictly prohibited.

If any discussion or action in violation of anti-trust statutes occurs, you should object, have your objection noted in the minutes of any meeting and, if the discussion or practice continues, leave the room. Further, the prohibitions apply to discussions in an informal or social setting, not just regularly scheduled meetings. If you see any prohibited practices at any APA meeting or social event, it is your duty to raise your concerns to a leader of the APA and/or APA General Counsel.

As part of our Antitrust Compliance Program, we remind members before each meeting that we will not engage in any conduct that could be construed as price fixing, bid rigging,



customer allocations or group boycotts, or in any way might be considered an unreasonable restraint on trade.

If you have any questions regarding our Antitrust Compliance Policy, please contact APA's General Counsel. This is a very serious matter and your cooperation and adherence to these policies are expected.

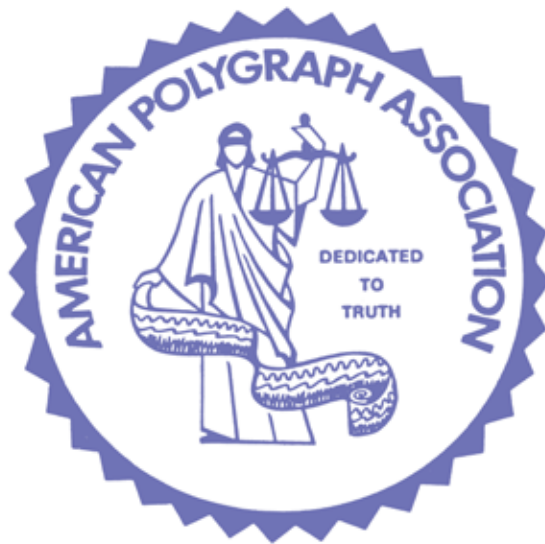



AMERICAN POLYGRAPH ASSOCIATION

CERTIFICATE

OF

NON-PROFIT CORPORATION

ARTICLES OF INCORPORATION

OF

AMERICAN POLYGRAPH ASSOCIATION

DEDICATED TO TRUTH

AUG 18 2003



662795

OFFICE OF RECORDER OF DEEDS, D. C.
Corporation Division
Sixth and D Streets, N. W.
Washington, D. C. 20001

CERTIFICATE

THIS IS TO CERTIFY that all provisions of the District of Columbia
Non-profit Corporation Act have been complied with and ACCORD-
INGLY this Certificate of Incorporation

is hereby issued to the AMERICAN POLYGRAPH ASSOCIATION

as of the date hereinafter mentioned.

Date **December 29, 1966.**



PETER S. RIDLEY,
Recorder of Deeds, D. C.
Alfred Goldstein
Alfred Goldstein
Superintendent of Corporations

Government of the District of Columbia
Form ED-C 53
Oct. 1962

From the Board



FILING FEE \$ 10.00
INDEXING FEE \$ 2.00

ARTICLES OF INCORPORATION
OF
AMERICAN POLYGRAPH ASSOCIATION

To: The Recorder of Deeds, D.C.
Washington, D. C.

We, the undersigned natural persons of the age of twenty-one years or more, acting as incorporators of a corporation adopt the following Articles of Incorporation for such corporation pursuant to the District of Columbia Non-profit Corporation Act:

FIRST: The name of the corporation is AMERICAN POLYGRAPH ASSOCIATION.

SECOND: The period of duration is perpetual.

THIRD: The objectives of the APA are that of advancing the use of the polygraph as a science and a profession, and of serving as a means for establishing unity in the polygraph field. The APA attempt to secure these objectives by disseminating information concerning polygraph instrumentation and techniques to its membership, by holding annual seminars, by promoting the free interchange of technical data among membership, and by providing a central source for information concerning the polygraph field. The organization further works toward defending the polygraph against its detractors, and toward establishing standards for training, ethics, and professionalism which will prevent the misuse of polygraph instruments or techniques by incompetent, unethical, or unprofessional individuals.

FOURTH: The corporation shall have members divided into such classes and with rights as to voting as set forth in the by-laws.

FIFTH: The Directors and Officers will be elected or appointed as set forth in the by-laws.

SIXTH: In the event of dissolution or termination of the corporation title to and possession of all the property of the corporation shall be transferred, conveyed, or distributed in accordance with the provisions of the District of Columbia Non-profit Corporation Act. The corporation reserves the right to amend, alter, or change any provisions contained in this certificate of incorporation in any manner prescribed by statute, and all rights conferred on members herein are granted subject to this reservation.

SEVENTH: The address of the initial registered office is
1038 Evarts St. N.E., Washington, D. C. 20018

and the name of the initial registered agent is
Raymond J. Weir Jr

FILED
DEC 29 1966
BY: WJR



EIGHTH: The number of directors constituting the initial board of directors is eleven (11) and their names and address are as follows and they will serve until their successors are elected or appointed:

Walter F. Atwood
Box 7599
Washington, D.C. 20044

H. N. Schladt
P. O. Drawer 40
Odenton, Maryland 21113

William Armstrong
1200 Clark St
St Louis, Mo. 63103

W. A. Van De Werken
3758 W. Belmont Ave
Chicago, Ill. 60618

J. Kirk Barefoot
155 E. 44th St
New York, N. Y. 10017

Raymond J. Weir Jr
1038 Evarts St. N. E.
Washington, D.C. 20018

C. B. Hanscom
2030 University Ave S.E.
Minneapolis, Minn. 55455

Dee E. Wheeler
1030 Burnet St
Fort Worth, Texas.

Warren Holmes
5210 W. Flagler
Miami, Florida

Lincoln M. Zonn
2 Park Ave
New York, N.Y. 10016

John E. Reid
600 South Michigan Ave
Chicago, Ill.

NINTH: The name and address of each incorporator is:

Walter F. Atwood 3105 Gumwood Dr Hyattsville, Maryland
Robert S. Eichelberger 4301 Massachusetts Ave N.W. Washington, D.C.
Raymond J. Weir Jr 1038 Evarts St. N.E. Washington, D. C.

Walter F. Atwood
Robert S. Eichelberger
Raymond J. Weir Jr

DATE December 17, 1966

I, Mary M. Cole, a Notary Public, hereby certify that on the 17th day of December 1966, personally appeared before me, Walter F. Atwood, Robert S. Eichelberger, Raymond J. Weir Jr, who signed the foregoing document as incorporators, and that the statements therein contained are true.

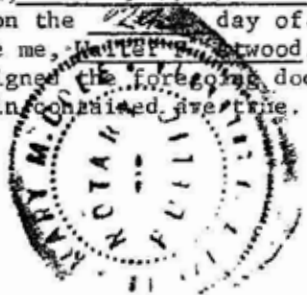

Mary M. Cole
Notary Public



This is to certify that the pages attached hereto constitute a full, true, and complete copy of CERTIFICATE AND ARTICLES OF INCORPORATION OF AMERICAN POLYGRAPH ASSOCIATION, AS RECEIVED AND FILED DECEMBER 29, 1966.

as the same appears of record in this office.

In Testimony Whereof,

I have hereunto set my hand and caused the seal of this office to be affixed, this

the 9th day of

September A. D. 1976.

PETER S. RIDLEY,
Recorder of Deeds, D. C.

By David H. Cole
ACTING Deputy Recorder of Deeds, D. C.

P-4290



Board Of Directors Of The American Polygraph Association

Public Censure

The Board of Directors of the American Polygraph Association (APA) voted on August 28, 2015, to publicly censure, APA member Laura Wells based on violation of APA Bylaw 4.8.1. This censure is based on a finding by the APA Ethics & Grievance Committee and adopted by the APA Board of Directors that, as director of a polygraph school, advertised via the school's website that it was accredited by the APA after such accreditation was revoked and continued to maintain on the website the representation that the school was accredited by the APA after being notified that such advertisement should be removed.

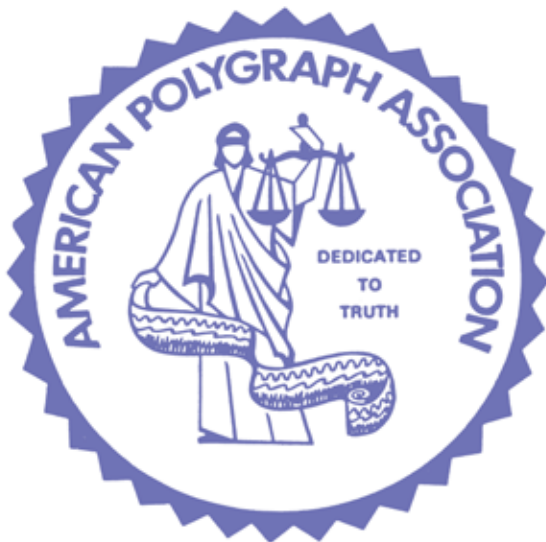

Mosso Respiration Recorder 1898

By Donald Krapohl

It is one of the respiration recorders used by Angelo Mosso. The subject would lie down where the circle is shown in the image, with the vertical post resting on the subject's chest. The rising and falling of the chest would directly move a long recording pen up and down across the moving recording drum of the kymographion.

There were other ways of monitoring respiration during that era, including the Marey and the Fitz pneumographs.

The attached image is the only reference to this particular design I have ever encountered. It is taken from a text Mosso wrote about high elevation physiology.

Citation: Angelo Mosso (1898). Life of man on the high Alps. Translated from the second edition of the Italian by E.

Lough Kiesow. T. Fisher Unwin: London.

You can also locate this image on the free site www.archive.org.

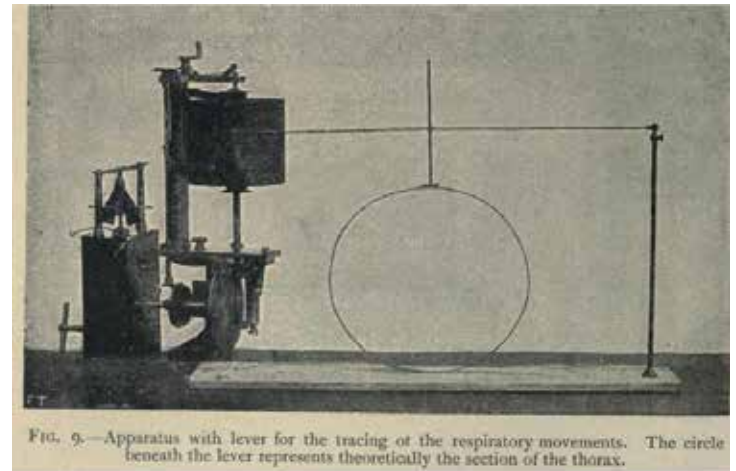

FIG. 9.—Apparatus with lever for the tracing of the respiratory movements. The circle beneath the lever represents theoretically the section of the thorax.

Employment

Lee County Sheriff's Office- Fort Myers, Florida

The Lee County Sheriff's Office (Ft. Myers) Florida, is accepting letters of interest and resumes for a full time Civilian Polygraph Examiner who graduated from an APA accredited polygraph school. Salary is \$39,067-\$75,000 plus state retirement. Must have as a minimum, a Bachelor's Degree or two (2) year college degree AND proof of three (3) years investigative experience (including interrogation and interview) or five (5) years investigative experience in Law Enforcement (including interrogation and interview) and a high school diploma. Directed Lie Screening Test experience is preferred.

Interested examiners must send a letter of interest along with a resume to cturner@sheriffleefl.org or contact Cari Turner at (239) 477-1323 for any questions.



Practicum

Advances are made by answering questions
Discoveries are made by questioning answers

Confirmatory Polygraph Testing

By Tuvya T. Amsel PhD

This article is a synopsis of the Israeli Polygraph Examiner Association (IPEA) members' symposium on the topic held on June 18, 2015. As such it should not be considered in anyway as having any scientific validity.

Confirmatory Testing: "PDD examination used to verify the statements of suspects, witnesses, and victims" (Krapohl, Handler & Sturm, 2012).

Prologue

The confirmatory polygraph testing is being practiced in a variety of totally different circumstances in where the following example, which is based on common practice of Israeli Family Courts, is just one. Further examples of practice will be described down the article.

While the prolonged alimony and assets partition negotiation was still on, Ms. Moore sought the court's protection, allegedly her husband is harassing and abusing her and their children. In her supporting statement for the restraining order she detailed numerous incidents of said nature. The judge being aware of the ongoing negotiation

and suspecting that the request might be a negotiation tactic and manipulation, ordered the parties to take a polygraph examination to affirm the allegations (Young, 1999). Ms. Moore's statement described numerous minor incidents, which separately were meaningless and harmless, but when put together created a different picture. Somewhat like a puzzle in which a single piece cannot project the full picture, the appointed polygraph examiner was left with no choice but to give the parties a confirmatory polygraph examination in an effort to verify the veracity of their statements. The reason to do so was to avoid doing numerous single-issue tests on each described incident; a procedure that

The author is a private examiner in Israel, and a regular contributor to the publications of the American Polygraph Association. The views expressed in this column are solely those of the author, and do not necessarily represent those of the American Polygraph Association. Publishable comments and replies regarding this column can be sent to editor@polygraph.org.



could have taken endless testing that may cause the examinees to lose their attention and affect the outcome.

Confirmatory testing case types

In a confirmatory polygraph testing the focus of the relevant and comparison questions are being diverted from the act / incident / event to the veracity of the statement that describe that event. For example in a case of a parent suspected of killing her/his child instead of asking the relevant question "Have you strangled ...?" The suspect will be asked to write a statement describing the incident and then the relevant question will be: "Have you lied in any of the details that you have described in your statement?" A comparison question might be: "Have you given a false statement in the past?"

These are the instances in were confirmatory testing is being recommended (Ginton, 2015):

- Multiple issues – When there is a need to confirm the veracity of a statement describing various types and numerous incidents as described above.
- Victims or suspects of a traumatic incident such as a rape victim or a parent suspected of killing her/his child in order to avoid the provocation of emotions that may follow a direct relevant question which in return may lead to a false positive outcome.
- Retesting – When testing and retesting fails to produce conclusive results an additional confirmatory re-test may be the solution.
- Nonfactual statements – Such as in where intentions, ambiguous suspicious and alike are described and cannot be examined.

The practice

IPEA members were advised to the following practice (Amsel, 2015):

- In the pretest ask the examinee to repeat her/his statement
- Disregard the original statement and test only on what the examinee stated during the pretest if s/he covered most of the original statement issues and test ONLY on what the examinee remembered in the pretest
- Ask the examinee to write down her/his pretest statement
- Phrase the relevant questions
- Phrase the control questions
- Pin the statement to the wall facing the examinee (or put it on the table next to the examinee's hand)
- Execute the test as a single issue test
- If the examinee was found deceptive discuss and try to locate the disturbing areas with her/him and then if possible perform an additional test with direct relevant questions

Special concern regarding the multiple issues confirmatory testing

Judges send sometimes parties to take confirmatory tests on statements which sometimes include many different incidents. The question begs, how many incidents should a tested statement include or should there be any limitation to the number of included incidents in a single statement?

Pro limitation arguments

- The examinee's ability to focus her/



his attention on numerous incidents simultaneously is limited, which can lead to a false negative or an inconclusive outcome due to the examinee uncertainty.

- If the examinee is deceptive in a minor and trivial fact which has no impact on the veracity of the statement as a whole s/he may still fail the test.
- The more incidents and/or issues there is, the possibility of examinee's uncertainty grows which can lead to false negative, false-positive or an inconclusive result.

Contra limitation arguments

- Summarizing the statement into a single question simplifies the test for the examinee so instead of spreading her/his attention to multiple incidents / issues s/he focuses on a single question.
- During the pretest interview while discussing each incident / issue separately, the examinee is conscious if s/he is truthful or deceptive. That knowledge should evoke the responses in the test itself when asked if s/he lied in her/his statement.
- Minimizing the test into a single question enable the examinee to be more focused.

Conclusion

The symposium participants agreed that the confirmatory polygraph testing is a "bench player" and therefore should be used only in the unique situations described above. The participants raised the following concerns:

- Confirmatory polygraph testing scientific validity has not been established.
- End users are skeptical and respond

suspiciously to its results. Direct relevant questions such as: "Have you killed...?" are by far more convincing than: "Have you lied in you statement?" even though the statement clearly says: "I have not killed....". End users voiced their concern and said that they feel as if like the confirmatory testing questions places an emotional buffer that allows the examinee to somehow escape responsibility from their act - which is not the case in the direct relevant questions.

Yet, as in sports, performing arts and the like, sometimes the circumstances leave the coach / director with no other choice but to use the substitute and when doing so examiners have to follow the above described practice.

References

- Amsel, T (2015)., "Confirmatory Testing Practice", Presentation to the Israeli Polygraph Examiners Association, Ramat Gan, July 18th 2015.
- Ginton, A. (2015), "Confirmatory Testing", Presentation to the Israeli Polygraph Examiners Association, Ramat Gan, July 18th 2015.
- Krapohl, D., Handler, M. & Sturm, S., (2012) Terminology Reference for the Science of Psychophysiological Detection of Deception, 3rd Edition, 2012.
- Young, C., (1999), "The Abuse of Restraining Orders", The Boston Globe



APPROVED FOR RELEASE 1994
CIA HISTORICAL REVIEW PROGRAM
18 SEPT 95

TITLE: The Polygraph In Agent Interrogation

AUTHOR: Chester C. Crawford

VOLUME: 4 ISSUE: Summer YEAR: 1960



STUDIES IN INTELLIGENCE



A collection of articles on the historical, operational, doctrinal, and theoretical aspects of intelligence.

All statements of fact, opinion or analysis expressed in Studies in Intelligence are those of the authors. They do not necessarily reflect official positions or views of the Central Intelligence Agency or any other US Government entity, past or present. Nothing in the contents should be construed as asserting or implying US Government endorsement of an article's factual statements and interpretations.



~~SECRET~~

Some past results and future prospects for technical instruments to sense deception.

THE POLYGRAPH IN AGENT INTERROGATION

Chester C. Crawford

Philosophers and psychologists, and indeed most of mankind, have always been fascinated with the phenomenon of lying as an aspect of human behavior. It is only during the past sixty years, however, that researchers and investigators have proceeded beyond the study of its cognitive phase (the decision to lie) and behavioral phase (the overt act which deceives) to examine its emotional phase (the ensuing bodily agitation), which is the most significant of the three for purposes of detection. It is therefore only recently that attempts to detect deception have advanced from the uncertainty of personal judgment and the brutality of primitive physical ordeals and torture to the use of scientific aids in humane interrogation. The "lie detector" or polygraph in use today, a simple but sensitive device for tracing blood pressure, respiration, and perspiration, is the most advanced instrument thus far developed for the detection of deception.

Deception is intrinsic to espionage activity: the ability of a clandestine operator to deceive his opponent is his most critical qualification. Conversely, however, the ability to detect the deceptions of the opposition is the most critical requirement of a counterintelligence force, and it was inevitable that the polygraph would become a counterintelligence aid. Although the use of this instrumental technique is associated in the popular mind primarily with criminal apprehension, the history of its application in clandestine government operations is almost as long as that of its connection with police matters.

One of the first plans for instrumental means to detect deception was in connection with clandestine operations. In October 1917, at the request of the Psychological Committee of the National Research Council, research was undertaken at Harvard University to investigate the value of using instru-

~~SECRET~~

31

ments in deception tests on World War I court-martial cases and in Military Intelligence Department investigations of suspected enemy agents. Early in World War II an officer of the Berkeley Police Department in California advocated the use of the lie detector in the interests of national defense. In 1945 Leonarde Keeler carried out polygraphic experimentation on several hundred prisoners of war in Rhode Island with an eye to assessing the practicability of lie detection programs in government agencies.

Successes of a CIA Program

On 12 August 1948 CIA ran its first polygraph case—the routine security screening of an applicant. In 1949 it began planning the use of the technique in Europe to test the honesty of agents recruited for clandestine operations. In 1951 it conducted polygraph experiments in the Far East. By 1952 the CIA polygraph program was operating on a world-wide basis. Its effectiveness in practice has firmly established it as a valuable adjunct to clandestine operations.

Its achievements can be illustrated in three studies analyzing the results of polygraphic interrogation over sample periods of time in operational cases from particular geographical areas. The first, covering the period from inauguration to 1953, is based on the area interrogators' reports for some three hundred cases. The use of the polygraphic technique elicited not otherwise obtainable admissions of deception in the following categories from the indicated numbers of the 300 agents.

| | |
|---|----|
| Falsification of vital statistics (age, birthplace, employment, education, etc.) | 32 |
| Concealment of past membership in Communist and Communist-front organizations | 16 |
| Concealment of other past Communist activities | 23 |
| Deception regarding past association with hostile or friendly foreign intelligence services | 18 |
| Deception regarding past criminal arrests | 22 |
| Concealment of past undetected crimes | 17 |
| Concealment of aliases | 11 |
| Deception regarding security violations | 23 |
| Deception regarding medical or mental treatment | 4 |
| The filing of false reports | 4 |
| Deception regarding use of drugs | 21 |

In addition, 21 instances of deception indicated by the polygraph but not admitted were later confirmed through other sources. Only 6 instances of indicated deception remained unconfirmed.

Thus more than one in ten of the agents and prospective agents had deliberately falsified his biographic data; honest biographic mistakes were not counted as deception. More significantly, six percent of them had hidden their past connections with other intelligence services. It is obvious that without polygraphic interrogation this sample of 300 could not have been properly assessed.

In another study 123 agent interrogation reports made in a different geographic area from January to December 1958 were carefully examined. With the aid of the polygraph the interrogators had obtained previously unknown information in the following categories from the indicated numbers of the 123 subjects:

| | |
|--|----|
| Biographic information | 61 |
| Counterespionage information | 17 |
| Past employment by a foreign intelligence service | 8 |
| Present employment by a foreign intelligence service | 4 |
| Fabrication of reports | 5 |
| Hidden ideological affiliations | 5 |

This time at least half the agents were shown to have practiced deception of some kind, and the percentage is still higher if the 61 listed as having misrepresented their biographies does not include all the deceivers in other categories. Six percent had worked for foreign intelligence services, and three percent were still so employed. At least ten agents were terminated as a result of these polygraph interviews. But about fifty—and this is an important positive product of the polygraph technique—were cleared of allegations that had been made against them.

The third study covers 70 agents interrogated between January and June 1959, who revealed previously unknown information as follows:

| | |
|---|----|
| Biographic information | 24 |
| Counterespionage information | 2 |
| Past employment by another service | 10 |
| Current employment by another service | 5 |
| Fabrication of operational reports | 11 |
| Hidden ideological affiliations (usually Communistic) | 6 |



Here at least one agent in every three was shown to have practiced deception of some kind. One in seven was found to have had past connections with other intelligence services and one in fourteen to have current affiliations. The polygraph interrogations led to the termination of at least five of them, and twenty-three were cleared of allegations against them.

In summary, out of about five hundred agents and prospects whose polygraphic interrogations were analyzed in these three studies, from ten to fifty percent revealed deceptions of some significance. A total of thirty-six agents were shown to have previously unknown connections with other intelligence services, some of them current affiliations which presumably made them instruments of infiltration.

Procedures and Limitations

It should be strongly emphasized that these results, although unobtainable without the polygraph, must not be credited to the polygraph *in vacuo*. They were achieved by professional interrogators using the instrument as an aid to diagnose deception in their agent subjects. The interrogator is thoroughly briefed on all aspects of the subject's personality, from sense of humor to skill at sports, on all available biographic data, on questionable and verified items in the subject's account of his background, and on the extent of his access to other intelligence services. He studies the reports from any previous medical or psychiatric examinations and from any previous interrogations, particularly any previous polygraph tests. In consultation with the case officer he determines the topics to be covered in the test and constructs questions designed to elicit information on them. He is prepared to probe for detail regarding the *modus operandi*, personnel, and tradecraft of a foreign intelligence service with which the subject is suspected of having past or present contacts.

The examination begins with a pre-test period in which the interrogator and the subject preview the questions for discussion and qualification. The examiner often takes advantage of this opportunity to make his own first-hand assessment of the subject, chatting about apparently unimportant matters and watching for any tell-tale reactions or idiosyn-

cracies that may be exploited in the test. The polygraph is then connected and the test itself administered—perhaps twice, four times, or on occasion many more. Then, when indicated by a study of the charts, there follows a post-test interrogation wherein an explanation, admission, or clarification of recorded emotional responses is sought.

The polygraph lays no claim to one-hundred-percent reliability. Test results can be as varied as the individuals tested, and the interpretation of the charts is not a simple question of deciding whether the subject reacted or did not react. Many charts are quite definitive; but some indicate only a probability, and from two to five percent of the cases tested end up being classified as inconclusive, with crucial areas left unresolved.

Although sources of error in the instrument itself can be eliminated—it is not hard to maintain a perfectly functioning machine—the human variables in the interrogator and the subject are less easily controlled. And while error potential in the interrogator can be reduced by careful selection and long training, the endless variety of human subjects and their endless variety of reactions to human situations will not ever be subject to measurement with infallible precision. Different subjects tend to put different weights on the value of individual questions; deceivers may show emotional disturbance only at the points where they know their fabrication is weakest, and sometimes not even then.

For all this reservation, the polygraph technique has established its place in clandestine operations. Although in many situations there is no need for polygraphic scrutiny, the problem of veracity being more easily resolvable through other sources, in many others, as these studies show, the duplicity of an agent cannot be discovered without the use of the polygraph. Add to these revelations the previously unknown information of a positive nature that is a by-product of an agent's polygraph test and the many cases of confirmed veracity that enable a project to get under way, and the value of the technique to clandestine operations becomes a thing beyond debate.

A more general dividend realized from the polygraph is its disciplinary effect on the agent. He is usually a better clan-



destine operator after being polygraphed. He realizes that he is working for a highly professional service, concerned about security for itself and for him. He sees that he will be expected to account for his activities. Loyal agents almost always appreciate this attitude and look with greater respect on the American service after their "ordeal."

An even greater role may be played by the technical detection of deception in clandestine operations of the future. There are indications that sensational developments are about to occur in its instrumentation, and drastic changes in technique made possible by the utilization of new recording devices. The polygraph of the future may require no physical attachments on the subject, perhaps utilizing electronic circuitry to tap physiological phenomena far more subtle but every bit as diagnostic as the currently used blood pressure tracings, respiration recordings, etc. It is unlikely that improvements will ever fully eliminate the human variables that make any technical assessment less than infallible, but a paper written on this subject ten years from now may show the uncertainties and limitations still further reduced.

BIBLIOGRAPHY

- Barioux, M., *Method for the Selection, Training and Evaluation of Interviewers*. Public Opinion Quarterly, Vol. 16, No. 1:128-130, 1952.
- Benfield, Wilder, *The Interpretive Cortex*, Science, 26 June 1959, Vol. 129, No. 3365, pp. 1719-1725.
- Best, Charles Herbert and Taylor, Norman Burke, *The Physiological Basis of Medical Practice*, Williams & Wilkins Company, Baltimore, 1955, Sixth Edition, pp. 1096-1098.
- Biderman, A. D., *Communist Techniques of Coercive Interrogation*, Air Intelligence Digest, 8:12-17, July 1955.
- Bledsoe, Anthony H., *The Lie Detector and National Defense*, San Francisco Police & Peace Officers Journal, 12 February 1941.
- Conklin, E. S., *Principles of Abnormal Psychology*, Henry Holt & Company, 1944.
- Dana, Homer J. and Barnett, Claude C., *A More Sensitive Means of Detecting and Recording Various Physiological Changes*, a paper presented before the meeting of the Instrument Society at Los Angeles, September 12 to 16, 1955.
- Dunbar, F., *Emotions and Bodily Changes*, New York, Columbia University Press, 1947.
- Ellson, D. G., *Detection of Deception*, Indiana University, Bloomington, Indiana, 1952, Office of Naval Research, Contract No. N6-ONR-180.

- Fitzgerald, M. J., *Handbook of Criminal Investigation*, New York, Greenberg, 1951.
- Gloglade, C., *Magic as the Origin of Lying and the Genesis of Thought*, Psychological Abstracts, Vol. 15, 1941, Abstr. No. 948.
- Gray, H., *Anatomy of the Human Body*, Philadelphia, Lea & Febiger, 1954.
- Hubbard, A. W., *Phrasing Questions; The Question of Bias in Interviewing*, Journal of Marketing, 15:48-56, July 1950.
- Inbau, Fred E. and Reid, J., *Lie Detection and Criminal Interrogation*, Baltimore, Williams & Wilkins Company, Third Edition, 1953.
- Karpman, Benjamin, *Lying—Ethics of Neurotic and Psychopathic Behavior*, Journal of Criminal Law and Criminology, July-August 1959, Vol. XI, No. 2.
- Keeler, Leonarde, *Debunking the "Lie Detector,"* Journal of Criminal Law and Criminology, Vol. XXV, No. 1, May-June 1934.
- Lamott, K., *Memoirs of a Brainwasher*, Harpers, 212:73-76, June 1956.
- Larson, John A., *Lying and Its Detection*, Chicago, University of Chicago Press, 1938.
- Levitt, Eugene E., *Scientific Evaluation of the Lie Detector*, Iowa Law Review, 1955, Vol. 40, pp. 440-458.
- Marston, William M., *The Lie Detector Test*, New York, Richard R. Smith Company, 1938.
- Marston, William M., *Psychological Possibilities in Deception Tests*, Journal of Criminal Law and Criminology, Vol. XI, No. 4, 552-553, 1921.
- Munn, N. L., *Psychology*, Boston, Houghton Mifflin Company, 1951.
- Reymert, M. L., *Feelings and Emotions*, New York, McGraw-Hill Book Company, 1950.
- Trovillo, P. V., *A History of Lie Detection*, Journal of Criminal Law and Criminology, 29 (6) 848 (1939).
- Trovillo, Paul V., *Report on Chatham Polygraph Program*, Russell Chatham Inc., Oak Ridge, Tennessee, April 14, 1951.
- U. S. Army General School, Fort Riley, Kansas, *Advanced Interrogation Techniques*, 1954.
- U. S. Army, Provost Marshal General's School, *Interviews and Interrogations*, Camp Gordon, Georgia, 1953.



Cheat Sheet for Using Normative Data and the Empirical Scoring System

Raymond Nelson and Mark Handler

1. **(Before conducting the exam) Locate the normative reference table for the test question format and test data analysis method**
 - Reference tables are error statistics that indicate the expected proportion of false-negative errors for truthful classifications and the expected proportions of false-positive errors for deceptive classifications
2. **(Before conducting the exam) Determine the alpha boundaries and numerical cutscores.**
 - Alpha is commonly set at .05
 - Alpha = .01 for increased precision (increased non-significant/inconclusive results)
 - Alpha = .10 for decreased inconclusive results (increase error rate)
 - Alpha is an administrative decision, often not determined by field practitioners
 - Locate the largest error statistic that is smaller than the required alpha boundary, then determine the numerical cutscore in the adjacent column
 - Alpha for truthful classifications
 - Alpha for deceptive classifications
 - For subtotal scores of diagnostic exams divide alpha by the number of RQs to get the Bonferroni corrected alpha. Then locate the largest error statistic that is smaller than the corrected alpha and determine the subtotal cutscore in the adjacent column
3. **(After conducting and scoring the exam) Calculate the test error statistic using the correct reference table for the exam format and scoring method**
 - Event-specific diagnostic exams
 - Grand total score: locate the grand total score and determine the p-value (probability of error) in the adjacent column
 - Sub-total scores: Locate the lowest sub-total score and determine the p-value in the adjacent column
 - Multiple issue screening exams
 - Negative scores: Locate the lowest sub-total score and determine the p-value in the adjacent column
 - Positive scores: Locate the lowest sub-total score and determine the Sidak corrected p-value in the correct column for the number of RQs
4. **Interpret the result (translate the numerical and statistical result into usable human language)**
 - Decision rules
 - Event-specific diagnostic exams
 - Grand total rule: simplest and most accurate
 - Two-stage rules: increased sensitivity and decreased inconclusives
 - Multi-issue screening exams
 - Sub-total score rule: use only the lowest sub-total score
 - Report the results:
 - Analysis method: evidence-based, norm-referenced, standardized
 - Numerical and statistical results: score, cutscore, p-value, alpha
 - Use of any statistical correction: Bonferroni or Sidak when used
 - What is the empirical meaning of the numerical and statistical result?
 - What is the simple categorical conclusion?



Classics in the History of Psychology

An internet resource developed by
Christopher D. Green
York University, Toronto, Ontario

Why Babe Ruth is Greatest Home-Run Hitter

Hugh S. Fullerton (1921)

Published in *Popular Science Monthly*, 99 (4), 19-21, 110.

[Classics Editor's note: This is not a well-known article now, but it is a prime example of the popularization of experimental psychology in the USA at the beginning of the 20th century. The story of its origin can be found in Alfred H. Fuchs' (1998) "Psychology and 'The Babe'", *Journal of the History of the Behavioral Sciences*, 34, 153-165. (N.B. Access to Interscience and Adobe Acrobat Reader capability required to browse article.) -cdg-]

Popular Science Monthly tests in the laboratory his brain, eye, ear, and muscle -- and gets his secret

The game was over. Babe, who had made one of his famous drives that day, was tired and wanted to go home. "Not tonight, Babe," I said. "Tonight you go to college with me. You're going to take scientific tests which will reveal your secret."

"Who wants to know it?" asked Babe.

"I want to know it," I replied, "and so do several hundred thousand fans. We want to know why it is that one man has achieved a unique batting skill like yours -- just why *you* can slam the ball as nobody else in the world can."

So away we went. Babe in his baseball uniform, not home to his armchair, but out to Columbia University to take his first college examination.

Babe went at the test with the zeal of a schoolboy, and the tests revealed why his rise to fame followed suddenly after years of playing during which he was known as an erratic although a powerful hitter. How he abruptly gained his unparalleled skill has been one of baseball's mysteries.

Albert Johanson, M.A., and Joseph Holmes, M.A., of the research laboratory of Columbia University's psychological department, who, in all probability, never saw Ruth hit a baseball, and who neither know or care if his batting average is .007 or .450, are .500 hitters in the psychology game. They led Babe Ruth into the great laboratory of the university, figuratively took him apart, watched the wheels go round; analyzed his brain, his eye, his ear, his muscles; studied how these worked together; reassembled him, and announced the exact reasons for his supremacy as a batter and a ball-player.





How fast does he swing?
How deep does he breathe?
The instrument at the left
measures the time from
the start of the swing
until the ball is struck.
The device at the right
records Ruth's breathing
over the same period of
time. By combining the
two readings, his total bat-
ting efficiency is measured.
The cross indicates height
at which Babe's ideal ball
is hit

Baseball employs scores of scouts to explore the country and discover baseball talent. These scouts are known as "Ivory hunters," and if baseball-club owners take the hint from the Ruth experiments, they can organize a clinic, submit candidates to the comprehensive tests undergone by Ruth, and discover whether or not other Ruths exist. By these tests it would be possible for the club owners to discover -- during the winter, perhaps -- whether the ball-players are liable to be good, bad, or mediocre; and, to carry the [p. 20] practical results of the experiments to the limit, then may be able to eliminate the possibility, or probability, of some player "pulling a boner" in mid-season by discovering, before the season starts, how liable he is to do so.

The scientific ivory hunters of Columbia University discovered that the secret of Babe Ruth's batting, reduced to non-scientific terms, is that his eyes and ears function more rapidly than those of other players; that his brain records sensations more quickly and transmits its orders to the muscles much faster than does that of the average man. The tests proved that the coordination of eye, brain, nerve system, and muscle is practically perfect, and that the reason he did not acquire his great batting power before the sudden burst at the beginning of the baseball season of 1920, was because, prior to that time, pitching and studying batters disturbed his almost perfect coordination.

Ruth the Superman

The tests revealed the fact that Ruth is 90 per cent efficient compared with a human average of 60 per cent.

That his eyes are about 12 per cent faster than those of the average human being.

That his ears function at least 10 per cent faster than those of the ordinary man. That his nerves are steadier than those of 499 out of 500 persons.

That in attention and quickness of perception he rated one and a half times above the human average.

That in intelligence, as demonstrated by the quickness and accuracy of understanding, he is



approximately 10 per cent above normal.

It must not be forgotten that the night on which the tests were made was an extremely warm one, and that in the afternoon he had played a hard, exhausting game of baseball before a large crowd, in the course of which he had made one of those home-run hits which we at Columbia were so eager to understand and account for. Under such circumstances, one would think that some signs of nerve exhaustion would be revealed. The instigation lasted more than three hours, during which Ruth stood for most of the time, walked up and down stairs five times, and underwent the tests in a close warm room. At the end of that time I was tired and nervous, and, although Ruth showed no symptoms of weariness, it is probable that under more favorable conditions his showing would have been even better.

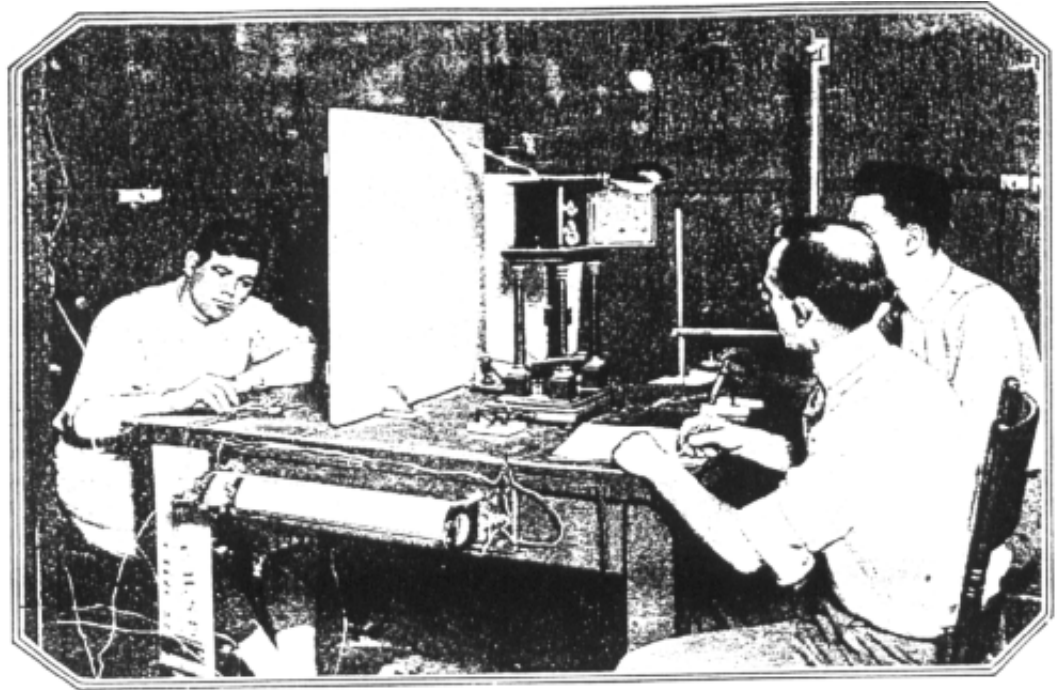

Testing Babe Ruth for Quickness of Eye, Brain and Muscle

Ruth was told to press the telegraph-key when a light flashed on the board before him. Results showed that his muscles responded to the eye-and-brain impulse more than one tenth quicker than do

those of the average person. Scientists say this is one reason why he can follow a sharp breaking curve with his bat and hit the ball fair enough to drive it far over the fence



Do you think you could place this stylus in the three holes on the triangular-shaped board in consecutive order 132 times a minute? Probably not, because the average is only 82; but the "home-run king" found no trouble in doing it, thus showing that his power of coordination is unusually great

The tests used were ones that primarily test motor functions and give a measure of the integrity of the psychophysical organism. Babe Ruth was posed first in an apparatus created to determine the strength, quickness, and approximate power of the swing of his bat against his ball. A plane covered with electrically charged wires, strung horizontally, was placed behind him and a ball was hung over the theoretical plate, so that it could be suspended at any desired height.

I learned something then which, perhaps, will interest the American League pitchers more than it will the scientists. This was that the ball Ruth likes best to hit, and can hit hardest, is a low ball pitched just above his knees on the outside corner of the plate. The scientists did not consider this of extreme importance in their calculations, but the pitchers will probably find it of great scientific interest.

Science Discovers the Secret

The ball was adjusted at the right height, and, taking up



a bat that was electrically wired, Ruth was told to get into position and to swing his bat exactly as if striking the ball for a home run, to make the end of it touch one of the transverse wires on the plate behind him, then swing it through its natural arc and hit the ball lightly. The bat, weighing fifty-four ounces (exactly the weight of the bats Ruth uses on the diamond), was swung as directed, touched the ball, and the secret of his power -- or, rather, the amount of force with which he strikes the ball -- was calculated. At least, the basis of the problem was secured: The bat, weighing fifty-four ounces, swinging at a rate of 110 feet a second, hits a ball travelling at the rate of, say, sixty feet a second, the ball weighing four and a quarter ounces, and striking the bat at a point four inches from the end. How far will it travel? There are other elements [p. 21] entering into the problem, such as the resilience of the ball, the "English" placed on it by the pitcher's hand, and a few minor details. But the answer, as proved by the measurements, is somewhere between 450 and 500 feet. This problem cannot be worked down to exact figures because of the unknown quantities.

The experimenters, however, were not so much interested in the problem in physics as they were in the problems in psychology. The thing they wanted to know was what made Ruth superior to all other ball-players in hitting power, rather than to measure that power.

Babe Could Beat His own Record!

Before proceeding to the psychological tests, however, we tried another in physics to satisfy my curiosity. A harness composed of rubber tubing was strapped around Ruth's chest and shoulders and attached by hollow tubes to a recording cylinder. By this means his breathing was recorded on a revolving disk. He was then placed in position to bat, an imaginary pitcher pitched an imaginary ball, and he went through the motions of hitting a home run. The test proved that, as a ball is pitched to him, Babe draws in his breath sharply as he makes the back-swing with his bat, and really "holds his breath" or suspends the operation of his breathing until after the ball is hit. But for that fact, he would hit the ball much harder and more effectively than he now does. It has been discovered that the act of drawing in the breath and holding it results in a sharp tension of the muscles and a consequent loss of striking power. If Ruth expelled his breath before striking the ball, the muscles would not become tense and his swing would have greater strength and rhythm.

The first test to discover the efficiency of his psychophysical organism was one designed to try his coordination; a simple little test. The scientists set up a triangular board, looking some thing like a ouija-board, with a small round hole at each angle. At the bottom of each hole was an electrified plate that registered every time it was touched. Ruth was presented with a little instrument that looked like a doll-sized curling iron, the end of which just fitted into the holes. Then he was told to take the instrument in his right hand and jab it into the holes successively, as often as he could in one minute, going around the board from left to right.

He grew interested at once. Here was something at which he could play. The professor "shushed" me, fearing that I would disturb Ruth or distract his attention as he started around the board, jabbing the curling-iron into the holes with great rapidity. He would put it into the holes twelve to sixteen times so perfectly that the instrument barely touched the sides. Then he would lose control and touch the sides, slowing down. Only twice did he pass the hole without getting the end of the iron into it. With his right hand he made a score of 122. Not unnaturally, his wrist was tired and Babe shook it and grinned ruefully.

Then he tried it with his left hand, scored 132 with it, proving himself a bit more left- than right-handed -- at least in some activities. The significance of the experiment, however, lies in the fact that the average of hundreds of persons who have taken that test is 82 to the minute, which shows how much swifter in the coordination of hand, brain, and eye Ruth is than the average.



Every Test but Another Triumph

In a sequel to this test that followed, Babe tapped an electrified plate with an electrically charged stylus with the speed of a drum-roll, scoring 193 taps per minute with his right hand and 176 with his left hand. The average score for right-handed persons undergoing this wrist-wracking experiment is 180, and, while there is no data covering right-handed persons using the left hand, it is certain that Ruth's record is much above the average, as he is highly efficient with the left hand.

But steadiness must accompany speed and so they tested the home-run king for his steadiness of nerve and muscle by having [p. 110] him thrust the useful little curling-iron stylus in different-sized holes pierced through an electrified plate which registered contacts between the stylus and the side of the hole. These measured respectively sixteen, eleven, nine, eight, and seven sixty-fourths of an inch; small enough, but not too small for Babe, for he made a score that showed him better than 499 persons out of 500.

The tests that interested me most were those to determine how quickly Ruth's eye acts and how quickly its signals are flashed through the brain to the muscles. Showing an amazingly quick reaction time, they interpreted what happens on the ball-field when the stands rock under the cheering that greets another of Ruth's smashes to the fence, proved an eye so quick that it sees the ball make an erratic curve and guides the bat to follow.

The scientists discovered exactly how quickly Ruth's eye functions by placing him in a dark cabinet, setting into operation a series of rapidly flashing bulbs and listening to the tick of an electric key by which he acknowledged the flashes.

The average man responds to the stimulus of the light in 180 one thousandths of a second. Babe Ruth needs only 160 one thousandths of a second. There is the same significance in the fact that Babe's response to the stimulus of sound comes 140 one thousandths of a second as against the average man's 150 thousandths.

Human beings differ very slightly in these sight and sound tests, or rather the fractions are so small that they seem inexpressive; yet a difference of 20 or 10 one thousandths of a second indicates a superiority of the highest importance.



Babe Ruth holds his breath when he bats. For that reason he is not getting the maximum force into his batting. This fact was recorded by the pneumatic tube around his chest that measured his breathing





A row of letters was exposed to view for one fifty thousandth of a second. The average person can note and read correctly four and one half letters in that time. But Babe Ruth read six out of eight letters

Translate the findings of the sight test into baseball if you want to see what they mean in Babe Ruth's case. They mean that a pitcher must throw a ball 20 one thousandths of a second faster to "fool" Babe than to "fool" the average person.

If the results of these tests at Columbia are a revelation to us, who know Ruth as a fast thinking player, they must be infinitely more amazing to the person who only comes into contact with the big fellow off the diamond and finds him unresponsive and even slow when some non-professional topic is under discussion.

The scientific "ivory hunters" up at Columbia demonstrated that Babe Ruth would have been the "home-run king" in almost any line of activity he chose to follow; that his brain would have won equal success for him had he drilled it for as long a time on some line entirely foreign to the national game. They did it, just as they proved his speed and his steadiness -- by simple laboratory tests.

For instance, they had an apparatus with a sort of a camera shutter arrangement that opened, winked, and closed at any desired speed. Cards with letters of the

alphabet on them were placed behind this shutter and exposed to view for one fifty-thousandth of a second. Ruth read them as they flashed into view, calling almost instantly the units of groups of three, four, five, and six letters. With eight shown he got the first six, and was uncertain of the others. The average person can see four and one half letters on the same test.

When cards marked with black dots were used, Ruth was even faster. He called up the number of dots on every card up to twelve without one mistake, The average person can see eight.

To test him for quickness of perception and understanding, he was given a card showing five different symbols -- a star, a cross, and three other shapes -- many times repeated, and was told to select a number -- one, two, three, four, or five -- for each symbol, then to mark the selected number under each one as rapidly as he could go over the card. He scored 103 hits on that test, which is the average of all who have tried it. But when given a card covered with printed matter and told to cross out all the a's, he made a score of sixty, which is one and a half times the average.

The secret of Babe Ruth's ability to hit is clearly revealed in these tests, His eye, his ear, his brain, his nerves all function more rapidly than do those of the average person. Further the coordination between eye, ear, brain, and muscle is much nearer perfection than that of the normal healthy man.

The scientific "ivory hunters" dissecting the "home-run king" discovered brain instead of bone, and showed how little mere luck, or even mere hitting strength, has to do with Ruth's phenomenal record.





© Fotolia.LLCbenedetti68

By Paul Woods

'A Brit's eye view of the 2015 APA Seminar'

Pounds or kilos, fahrenheit or centigrade, inches or centimeters, pavement or sidewalk? Just some of the dilemmas faced by those of us crossing the pond for the APA Annual Seminar. Having spent many months in the US over the last 30 years, I thought that I had mastered the art of those particular conundrums and then I arrived at an APA Seminar for the first time. My assumption had been, as is the norm at most conferences, that I would sit in a hall and be supplied with knowledge by 'osmosis'; with little if any heavy lifting on my part. How wrong could I be – 8am on Monday and faced with a choice – A, B or C? And then to compound the problem, simultaneous presentations of interest. How could I be in two places at once? Luckily Sunday's program did not require internal debate – one speaker – simple!



© Fotolia LLC /reshkova

And then, came yet more choice – PLC or DLC, Federal or ESS, or both? Different schools of thought based on personal preference, grounded perhaps in the professional origins of those who advocated for them. A bit like polygraph instrument selection – a choice usually linked to the one that the individual was introduced to at polygraph school (in the digital rather than analogue age), or the selection of whichever Department or Agency he





or she works for. It is all about choice and like most things in life; decisions are usually informed by biases, reason, emotions, and memories, and perhaps some subtle marketing! If such choice introduces uncertainty for the examiner, spare a thought for the consumer or examinee – assuming of course they have choice in the first place. For those of us in the private sector they certainly do – limited sometimes by the nuances of Google and more than likely informed by a perception gleaned from daytime TV shows rather than detailed analysis of the science itself.

Each to his or her own but at the end of the day, polygraph practitioners are duty bound to provide the best possible service with personal integrity, utilising the most reliable technology

and validated test formats available. Different formats provide alternate solutions for the examiner. What was clear from the Seminar proceedings was that the APA has attempted to support examiners and inform choice by its continued efforts to present the evidence underpinning each test format, and to provide a sustainable argument against those who would seek to undermine the profession.

Much was made of the meta-analysis during the event with a number of speakers referencing it in their individual presentations. As evident at the seminar, if there is a debate among polygraph examiners about formats, test data analysis and the relevance of the meta-analysis to the profession, spare a thought for those who either seek or are compelled to take an examination. One of the objectives of the Association through its publications and seminars such as the one in Chicago, must surely be to present polygraph objectively and to demystify it. Whilst there is a need to present the science to those who wish to engage with the profession at a legal or academic level, most of those who come into contact with the polygraph do not fall into those categories – lay people who require a level of detail commensurate with their individual circumstances. Presenting polygraph as some form of mysterious art helps no-one, and as mentioned so many times during the seminar, the internet



and a number of individuals are freely accessible repositories of a mountain of information about polygraph.

As an attendee I must compliment the APA on its choice of destination and hotel: an impressive City and conference venue. It was a pleasure to see such a diverse range of practitioners from so many countries within a single profession together in one place, all wanting to learn and share. In a host country where the MLB 'World Series' comprises just one country, the inclusive nature of both the event and Association was most welcome, but it also poses a challenge for the Board. How does it extend a professional Association so rooted in recent American history and culture into one that is truly international? As a past President of an International Institution, I recognise some of the

potential challenges and pitfalls that lie ahead for the Association, as well as those that are currently in train. An association is by definition a 'group of people organized for a joint purpose' or a 'connection or cooperative link between people'. Membership is voluntary and individuals have varying motivations for joining, any or all of which do not necessarily mean they will be active participants in the wider aims or ambitions of the Association. Individuals also have choice when it comes to Polygraph Association membership. Key to success is articulating the 'joint purpose', harnessing the collective contribution of the membership to achieve and all, hopefully by consensus. Any association is only as good as the sum of its parts. Some individuals may contribute more than others to the advancement of the



profession and be recognised for it, but the institution can only survive if its professional standing is recognised externally and its credibility remains intact. The maintenance of professional standards, competence, continuing professional development, and an unerring drive to demonstrate that those in this profession have equivalence to other technical professions should be the goal of all within the Association. It would be a huge bonus for those of us who are members to be able to use attendance at events such as the seminar and 'advanced' courses offered by many schools to build on a CPD platform that leads to higher level, externally recognised qualifications.

Here in the UK individuals have the opportunity in many professions such as engineers, lawyers and surveyors to achieve Chartered status; awarded to a person who has gained a high level of competence in a particular field of work and as such has been awarded a formal credential by an organization in recognition of that achievement. Chartered status is awarded usually by professional bodies and in general, Chartered qualifications are considered ultimate qualifications in a particular field of work. Chartered status originates from and is mainly awarded by Institutions that have been incorporated under Royal Charter by the British Monarch, hence its prevalent use in the UK and Commonwealth

countries, however some non-UK organisations have taken to issuing Chartered designations without Royal or Parliamentary approval.

As a personal observation intended to contribute to future proceedings and not intended as a criticism, I would have welcomed the opportunity to see the collected audience in a session aimed at engaging and challenging received wisdom. Debate is healthy within any professional institution and an Annual Seminar with so many contributors to polygraph development present in one place, must surely be an opportunity too good to miss. It might also provide an opportunity for the Board to set out its stall for the future and engage with its membership, outside of the formal business meeting process.

On a final note I would like to express my thanks to those who put the event together and looked after us all at the event.



Five Minute Science Lesson: Types of Scientific Studies

By Raymond Nelson



Case studies: anecdotal case studies are useful to illustrate points of existing knowledge, and are also useful to raise questions about our existing knowledge. Although they can be used to falsify a conclusion, case anecdotes are not an accepted basis on which to begin to accept a scientific conclusion. Case studies are used in the polygraph profession to both illustrate and teach applied testing principles, and are also used to raise questions about the limits of our present knowledge and capabilities.

Field studies: are valuable because they can help to answer scientific questions about the generalization of scientific results observed in controlled laboratory studies to field settings. Field studies are useful in the polygraph profession because they can be said to have ecological validity in that the study conditions are identical to field testing conditions. Field studies are useful to study questions of correlation. But because they cannot adequately control all testing conditions, field studies cannot be used to study questions



of causality. Field studies conducted using proper random sampling techniques generally provide results with wider margins of error than controlled laboratory studies. Random sampling is difficult to achieve in field research, and the potential for non-random sampling methods will mean that field study results should be compared to results from laboratory studies to more fully understand their meaning. Field polygraph studies that significantly outperform the results of laboratory studies should be carefully evaluated for confounded sampling methodology before the results are accepted.

Laboratory studies: the control-group laboratory study is a common form of research used to answer questions about effect sizes due to an experimental variable. The double-blind longitudinal control-group study is the gold standard for scientific research that attempts to answer questions about causality. However, double-blind longitudinal studies are expensive and difficult to achieve, and are sometimes not possible. For this reason, small scale laboratory studies are common in addition to other types of scientific study. An important advantage of laboratory research is the ability to achieve random assignment to experimental and control groups; the effect of this is to increase the

replicability and generalizability of study results. Study results based on non-random selection are notoriously non-replicable and not generalizable. Small-scale laboratory studies are commonly used in the polygraph profession.

Meta-analytic studies: provide a solution to the difficulty, expense and often impossibility of large double-blind longitudinal control-group studies by statistically combining the effect sizes from numerous smaller studies. The principles of meta-analysis assume that all sample results will imperfectly represent the population or universe, but will converge over time to a more precise estimate. Meta-analytic research is a structured process with requirements for explicit declaration of both research questions and the parameters for study inclusion and analysis. Meta-analytic principles can be used in polygraph research to systematically aggregate the results of previously published studies.

Monte Carlo studies: are a form of scientific studies that begins with some existing knowledge about the data problem and variance of the data problems, and uses powerful computers to answer research questions. This is accomplished by defining sophisticated mathematical, statistical, and computational models



that would be tedious or impossible to calculate manually. Monte Carlo studies can be used in a number of ways in polygraph research, including modeling outcomes, scoring distributions, and complex data problems.

Single-subject research designs: are useful when the goal of research is to answer questions about a single case that does not conform to existing norms. The individual in a single-subject research design will serve as his or her own control group. The goal in this type of research is often to identify individual differences whereas other research designs are more interested in group differences or group similarities. Single subject designs may be a useful in the polygraph profession as a form of exploratory research. Generalization of conclusions from single-subject designs is not realistic.

Program evaluation: is a form of research intended to answer questions about program effectiveness, possibly including both outcomes and operations. Program evaluation methods are often carefully structured, though may involve both quantitative and qualitative information. Research questions for program evaluation studies will often involve whether the program is achieving the intended

effect. Program evaluation research in the polygraph profession will generally take the form of accreditation, certification and quality assurance activities.

Survey research: is used to gather information that may be objective factual information, or may be subjective information such as thoughts or opinions. Information from survey research can be used in other types of studies to model or predict outcomes or trends. As with other forms of research, random sampling is fundamental to any attempt to achieve generalizable knowledge or information from survey research. Confounded or non-random sampling methods will lead to research results that do not replicate or generalize and are of little actual value. Survey research has been used in the polygraph profession in order to understand professional attitudes and characteristics, and also to provide additional information to evaluate quantitative polygraph research outcomes.

Thought experiment: a form of scientific activity used to think through the logical and/or mathematical consequences of an idea or activity. Thought experiments are useful in the polygraph and other professions for teaching concepts and ideas for which it may not be practical or possible to



actually conduct the experiment, and for which the results from a thought experiment will satisfactorily illustrate the ideas. Thought experiments can also be used to raise additional research questions. However, results from thought experiments should not be accepted unless the content of a thought experiment are based on facts supported by mathematical and logical proof. Generalization of conclusions is not possible when a thought experiment is based on conjecture, speculation or subjective opinion.

Although not an exhaustive description of all possible types of research, this short list is intended to introduce the reader to the types of studies that can be useful in polygraph research. There is no single type of research that is inherently superior or universally preferred over others. Instead, all types of scientific studies may offer some advantages. Additionally, all types of scientific research can include inherent disadvantages and limitations. Research in the polygraph profession and all fields of scientific inquiry will ideally leverage the advantages of all types of research designs. It will be a mistake for the polygraph profession to reject or neglect to use any of the available and accepted tools to answer our important scientific questions. Use of a complete variety of research

methods will allow us to benefit from the synergistic information that different methods can provide as we attempt to answer deep and difficult scientific questions such as those involving human interactions and the difference between deception and truth-telling.



Jan. 13, 1931.

L. KEELER

1,788,434

APPARATUS FOR RECORDING ARTERIAL BLOOD PRESSURE

Filed July 30, 1925

3 Sheets-Sheet 1

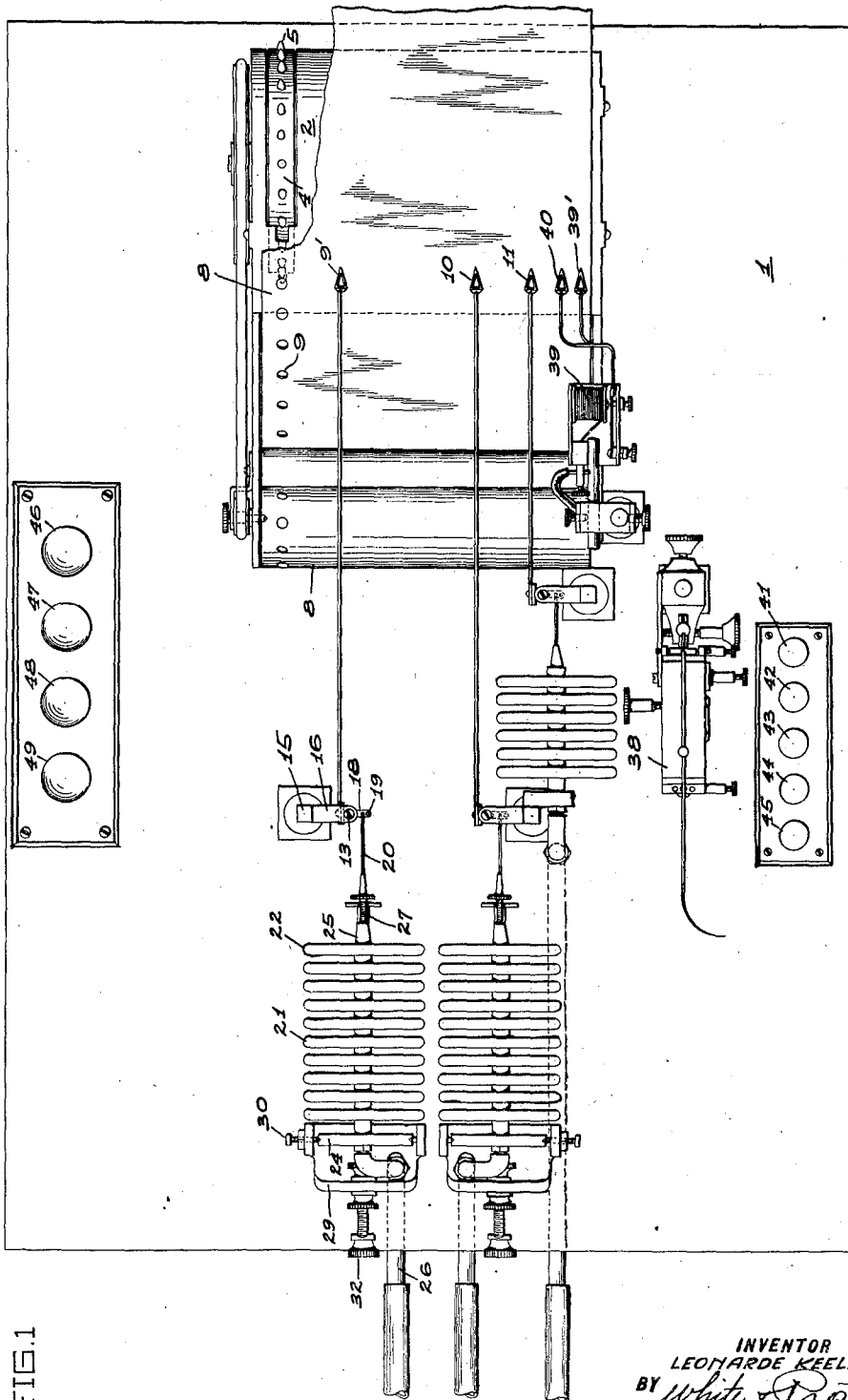

FIG. 1

INVENTOR
LEONARDE KEELER
BY *White & Root*
his ATTORNEYS

Jan. 13, 1931.

L. KEELER

1,788,434

APPARATUS FOR RECORDING ARTERIAL BLOOD PRESSURE

Filed July 30, 1925

3 Sheets-Sheet 2

FIG. 2

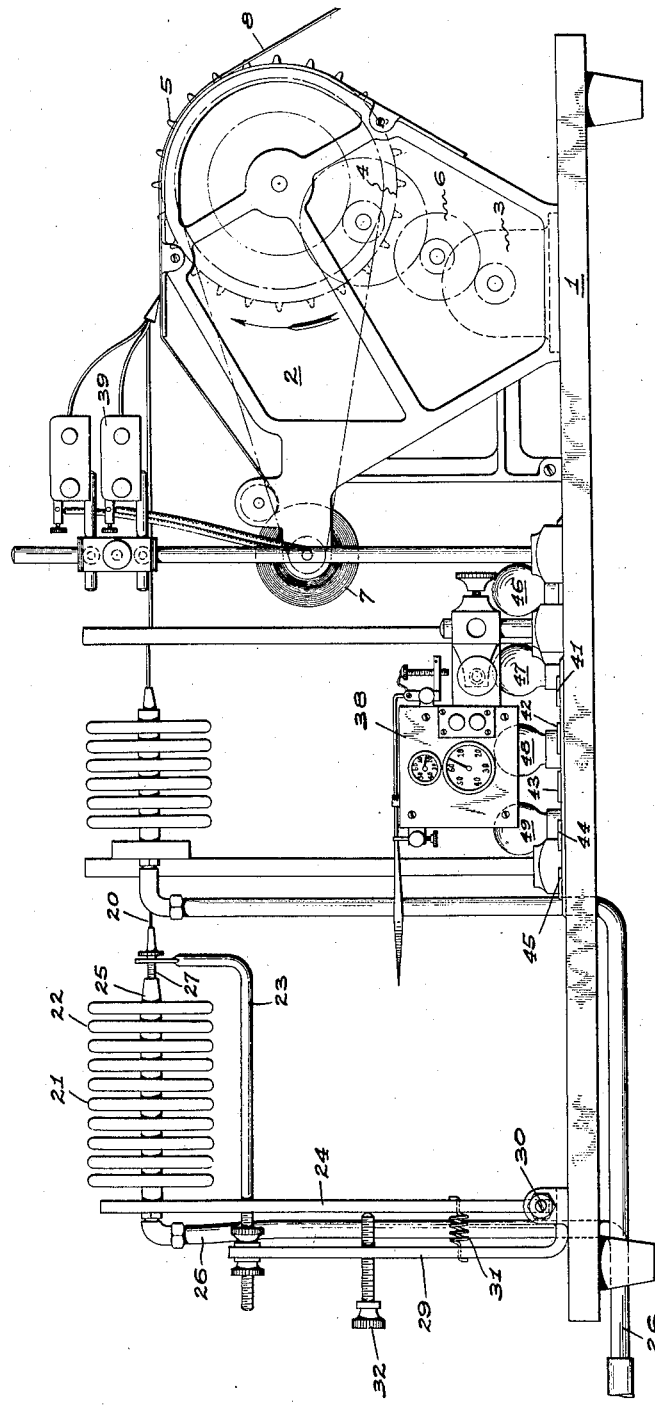
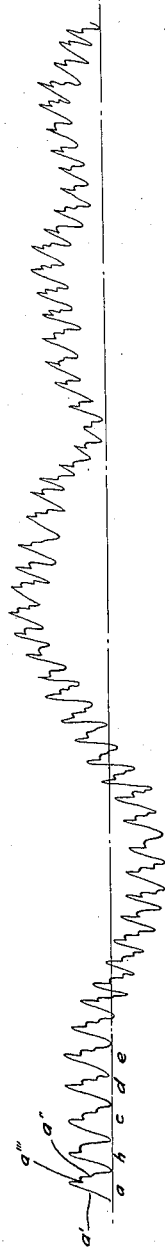

FIG. 6



INVENTOR
 LEONARDE KEELER
 BY *White & Post*
 his ATTORNEYS

Jan. 13, 1931.

L. KEELER

1,788,434

APPARATUS FOR RECORDING ARTERIAL BLOOD PRESSURE

Filed July 30, 1925

3 Sheets-Sheet 3

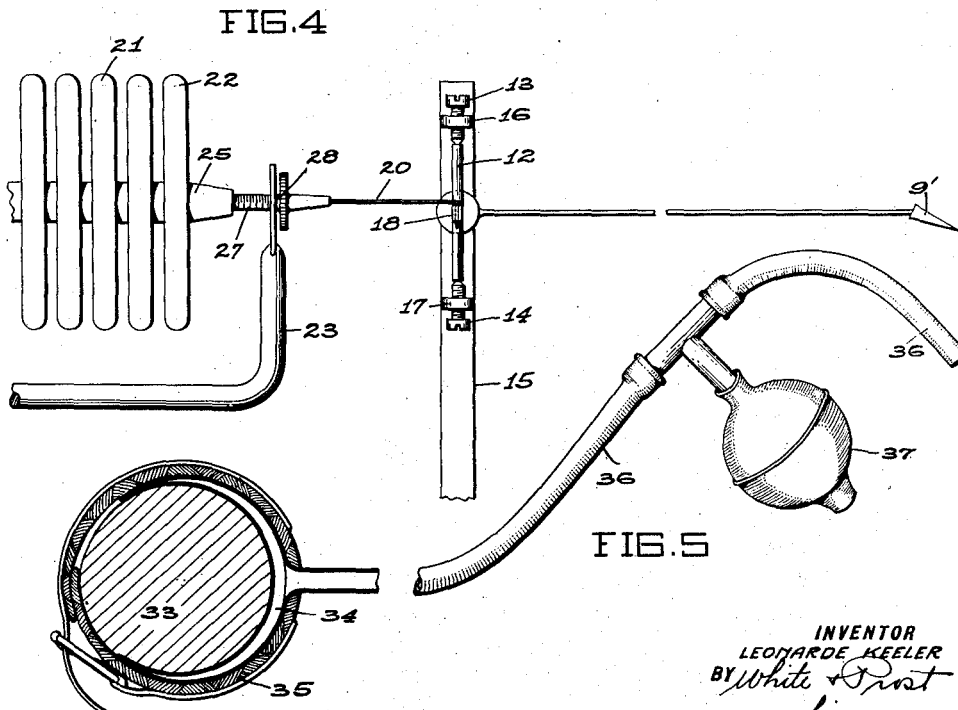
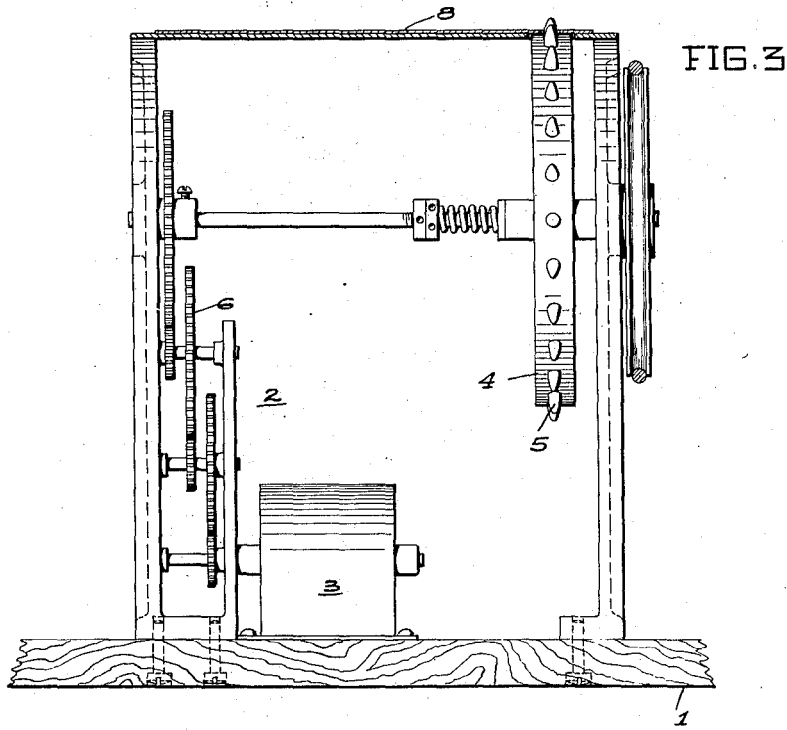

INVENTOR
LEONARDE KEELER
BY *White & Post*
his ATTORNEYS

UNITED STATES PATENT OFFICE

LEONARDE KEELER, OF BERKELEY, CALIFORNIA

APPARATUS FOR RECORDING ARTERIAL BLOOD PRESSURE

Application filed July 30, 1925. Serial No. 46,986.

This invention relates to means for recording cardiac cycles and other oscillations in arterial pressure simultaneously. Sphygmographs are well known in the art. Sphygmograms, or the series of connected curves recorded by a sphygmograph, indicate cardiac cycles only, in which the up stroke is the systole curve and the down stroke the diastole curve. In addition to the pressure oscillations of the cardiac cycle, there are slower oscillations, which are more or less irregular and which may be superimposed on a considerable number of cardiac cycles. The slower oscillations in the arterial pressure may be due to various factors such as for example, respiratory movements, rhythmic variations in the activity of the vasoconstrictor center or in the cardiac activity. Heretofore, it has not been possible to record graphically a curve combining the cardiac cycle, which showed the systolic and diastolic pressures and dicrotic notch and the slower oscillations, and it is an object of this invention to provide means for accomplishing this purpose. The curves referred to will be better understood from the detailed description hereinafter in connection with the drawings in which such curves are illustrated.

My invention also has been found of great value in connection with making certain psychological tests based on arterial blood pressure variations. In such cases I have simultaneously recorded with means embodying my invention two curves taken from different parts of the body, such for example, as the two arms, two legs, one arm and one leg, etc. My invention may also record a respiration curve, which curve is recorded simultaneously with the two aforesaid curves. An apparatus of this character will be more fully described hereinafter.

It is an object of the invention to provide means whereby the sphygmogram or cardiac cycle may be recorded simultaneously with and be superimposed on the slower oscillations in the arterial pressure, whereby the characteristics of each as well as their relation to each other at any moment may be readily ascertained.

The invention possesses other advantage-

ous features, some of which with the foregoing will be set forth at length in the following description where I shall outline in full that form of the invention which I have selected for illustration in the drawings accompanying and forming part of the present specification. In said drawings I have shown one form of device embodying my invention, but it is to be understood that I do not limit myself to such form, since the invention as set forth in the claims may be embodied in a plurality of other forms.

Referring to the drawings:

Figure 1 is a top plan view of apparatus embodying my invention.

Fig. 2 is a side elevation of the apparatus shown in Fig. 1.

Fig. 3 is an end view illustrating the mechanism of the kymograph.

Fig. 4 is an enlarged detail view illustrating the mechanism connecting a tambour unit with a stylus of the kymograph.

Fig. 5 is a cross-sectional view of a brachial cuff with the inflator and tubes shown in elevation: and

Fig. 6 illustrates an enlarged specimen of a graphic record obtained by my invention.

Apparatus embodying my invention is preferably mounted on a suitable base 1 and includes a kymograph 2, which comprises a motor 3 which drives a roller 4, having a plurality of teeth 5 on its periphery, through a suitable gear train indicated as a whole by the numeral 6. The kymograph is provided with a suitable supply roll 7, which carries smoked paper 8 or any other suitable medium for receiving records. The paper 8 is provided with holes 9 adapted to be engaged by the teeth 5 so as to draw the paper through the kymograph in a well understood manner. This apparatus is well known and does not of itself form a part of my invention as any standard type of apparatus for accomplishing the same result may be employed.

Records or graphs are traced on the paper 8 by a stylus of which three are shown, designated 9', 10 and 11, although it is to be understood that I do not limit myself to any particular number. Since each of the styli is actuated by similar mechanism embodying

my invention, a description of one will be sufficient, and will best be understood by referring to Figs. 1 and 4. The stylus 9' is secured at right angles to a small shaft 12, (Fig. 4) preferably at a point midway between the ends thereof, and the shaft is rotatably supported by two adjustable screws 13 and 14. Preferably the ends of the shaft are provided with conical depressions to receive the ends of said screws which are suitably pointed. The screws 13 and 14 are supported on a fixed vertical member 15 by two arms 16 and 17 and the axis of shaft 12 as it appears in Figure 1 is in a plane at right angles to the plane of paper 8, which is preferably horizontal as shown. The shaft 12 is provided with a small lever 18, positioned preferably at a point midway between the ends of the shaft. The lever 18 is provided with a hole 19 to receive a hook or L-shaped member 20. A plurality of holes 19 may be provided so that the member 20 may be placed in different ones for the purpose of adjusting the amount of leverage. The member 20 is connected in a manner hereinafter described to the end of a tambour unit 21, which comprises a series of metal tambours 22, whereby vibrations or motion transmitted to the tambours 22 may be transmitted to the stylus 9', the amplification of such motion or vibrations of course being determined by the lengths of the lever 18 and stylus 9'. The tambour unit 21 is supported at one end by an L-shaped member 23 and at its opposite end by a vertical member 24, as best shown in Fig. 2. The interiors of the tambours 22 are all in communication with each other. The tambour 22 adjacent the member 20 is closed, as indicated at 25 and the tambour 22 at the opposite end of the unit is open and connected with a pipe 26. For the purpose of maintaining the tambour unit 21 in any desired distended position, such for example as to correspond to a given pressure, adjusting means have been provided. These comprise the provision of a screw 27 which is swiveled on the end of member 20 and adapted to engage threads in the end 25 of the tambour unit 21, and a shoulder 28 (Fig. 4) bearing against the support 23. Thus when the screw 27 is rotated, the tambour unit 21 may be fixed in a given distended position with respect to the member 23. The L-shaped member is supported on a fixed vertical element 29 as shown in Fig. 2, and may extend through an opening in the member 24, not shown. The member 24 is pivotally connected to the base 1 at 30 and normally urged toward the fixed element 29 by a spring 31. The distance between the members 24 and 29 is regulated by a screw 32 in a manner readily understood. In this manner the end of the tambour unit adjacent the pipe 26 may also be held in a distended position. I preferably employ both the screws 27 and 32 for adjusting the tambour unit. The purpose of the adjustment

will be better understood from the following description. In Fig. 5, an arm of a person is indicated in cross-section at 33 which is partially surrounded by a rubber bag 34 held in position by a leather cuff 35. The rubber bag is connected by means of a suitable tube 36 with a pump 37 and with the pipe 26 which communicates with the interior of the tambour unit 21. The bag 34 is inflated by means of the pump 37 to a pressure at which pulsations impart a free motion to the stylus. As the stylus would now travel through a wide arc, and be likely to jump from the paper 8, the tambour unit 21 is adjusted in the manner described to a distended position corresponding to the pressure at this time. Thereafter the travel of the stylus is limited in a manner readily understood.

By means described, I secured a graphic record of the character shown in Fig. 6. Heretofore sphygmographs have been obtained showing the cardiac cycle which was similar to the first five cycles shown in Fig. 6 designated *a* to *e* inclusive, in which the upward line *a'* to the peak indicates the systolic pressure, the downward line *a''* the diastolic pressure and *a'''* the dicrotic notch. These cycles were uniform with respect to a given line. The applicant's invention, however, produces a new and additional result. While maintaining the individual characteristics of each cardiac cycle, the same are imposed upon a wave, which may rise or fall irregularly as shown in Fig. 6. It has been found that this wave may be varied by physical, psychological or emotional changes; however, the applicant does not undertake to analyze at this time the properties of the curve obtained. The same is the subject matter of study by the medical profession, and it is now known that the curve is different from any other curve heretofore obtained.

While my invention probably has its greatest application in the field of the medical profession, for purposes of illustration I have shown the same embodied in apparatus for making certain psychological tests. This apparatus is provided with two styli, 9' and 10, with associated mechanism similar to that above described; however, in one case the impulse transmitting means is connected with an arm and in the other case to the other arm or a leg or in each case said means are connected with a leg, whereby parallel records are obtained from different portions of the body. The stylus 11 is connected with means for recording a respiration curve. This apparatus may also comprise a clock-mechanism 38, which controls the circuit of an electromagnet 39 for indicating time intervals on the paper 8, said magnet actuating a stylus 39'. In carrying out the tests, the person under examination is subjected to questioning and his various reactions are

indicated in the graphs recorded. In order to indicate on the record the time when certain questions are asked, a time marking device is provided which comprises an electromagnetically actuated stylus 40, which may be controlled by a push button 41. Four other push buttons, 42, 43, 44 and 45 are also shown which control signal lamps 46, 47, 48 and 49 respectively so that a signal may be flashed to a remote point to indicate what the recorded graphs show. This arrangement is provided as the person conducting the examination may be at a distance from the device and not be able to read the indications, and thus avoid any conversation which may be heard by the person under examination. The particular construction shown is designed for use by the police in making criminal investigations.

I claim:

1. Apparatus of the character specified comprising a series of metal tambours, means for transmitting pressure to the same, a pivoted member supporting one end of said series, a fixed parallel member, means normally urging said pivoted member toward said fixed member, means for adjusting the distance between said fixed and pivoted members, a screw at the opposite end of said series of tambours, means for supporting said screw carried by said fixed member, a pin swiveled to said screw and an indicating lever actuated by said pin.

2. Apparatus of the character described comprising a pivoted indicating member, a series of connected metal tambours, means for transmitting pressure to said tambours, means for holding the tambours in a distended position, and means for transmitting the movements of said tambours to said indicating member, comprising an adjustable member secured to the end tambour of said series and engaging said indicating member.

3. Apparatus of the character described comprising a pivoted indicating member, a series of connected metal tambours, means for transmitting pressure to said tambours, means for holding the tambours in a distended position, means for transmitting the movements of said tambours to said indicating member comprising an adjustable member secured to the end tambour of said series and engaging said indicating member, and means for varying the position of the series of tambours with respect to said indicating element.

4. The method of indicating the psychological and physical condition of a patient comprising simultaneously recording both the cardiac cycle and general variations in blood pressure upon a single curve.

5. In a sphygmograph having pressure transmitting means adapted to be applied to the body of a patient for transmitting variations in blood pressure and a recording device; an actuating means interposed between

said first mentioned means and said recording device for actuating said recording device in response to blood pressure variations, said actuating means being so constructed and arranged that it is sensitive to fluctuations in the cardiac cycle and to fluctuations in blood pressure other than the cardiac cycle, whereby a continuous record is obtained comprising a curve of the blood pressure fluctuations having the cardiac cycle superposed thereon.

6. In a sphygmograph having pressure transmitting means adapted to be applied to the body of a patient for transmitting variations in blood pressure, and a recording device; an actuating means interposed between said first mentioned means and said recording device for actuating said recording device in response to blood pressure variations, said actuating means having freedom of movement over a range of pressure variations which includes the cardiac cyclic and arterial pressure variations, whereby a continuous record is obtained comprising a curve of the blood pressure fluctuations having the cardiac cycle superposed thereon.

7. In a sphygmograph having pressure transmitting means adapted to be applied to the body of a patient for transmitting variations in blood pressure, and a recording device; an actuating means interposed between said first mentioned means and said recording device for actuating said recording device in response to blood pressure variations, said actuating means having freedom of movement over a range of pressure variations which includes the cardiac cyclic and arterial pressure variations, and being substantially equally sensitive over said range, whereby a continuous record is obtained comprising a curve of the blood pressure fluctuations having the cardiac cycle superposed thereon.

8. In a sphygmograph having pressure transmitting means adapted to be applied to the body of the patient for transmitting variations in blood pressure, and a recording device; an actuating means interposed between said first mentioned means and said recording device for actuating said recording device in response to blood pressure variations, said actuating means comprising a series of metal tambours so constructed and arranged that the recording device is responsive to cardiac cyclic fluctuations and arterial pressure variations, whereby a continuous record is obtained comprising a curve of the arterial pressure having a cardiac cycle superposed thereon.

In testimony whereof, I have hereunto set my hand.

LEONARDE KEELER.

Book Review of Donald Krapohl and Pamela Shaw's *Fundamentals of Polygraph Practice* by Mark Handler

I was fortunate enough to receive an offer to review the new Krapohl & Shaw 2015 polygraph handbook. The book is a comprehensive review of polygraph in general. It begins with a well researched chapter on the history of lie detection that corrects a number of long held errors perpetuated through lore. The history chapter covers ancient traditions based on behavioral and physiological observations. It moves through the experimental instrumentation that paved the way to current polygraph instruments. Finally it provides a background of the evolution of polygraph techniques, including data collection and analysis models.

The polygraph physiology chapter was authored by Professor Joel Reicherter, one of the leading authorities on the subject. The chapter focuses on those aspect of physiology that are directly related to polygraph. Joel has a wonderful way of communicating and delivering this potentially difficult material to the student, practitioner or consumer. The chapter is a great refresher for examiners and could easily function as the base training material for all polygraph school physiology courses. The diagrams are excellent and well compliment the writing.

The third chapter covers test question construction beliefs. There is little empirical support in this area so the reader should consider this section the opinions and suggestions of the authors. They provide an overview of conventional beliefs and teachings on this subject. They cover a multitude of question types that would be beneficial to polygraph consumers and end-users who may misunderstand test questions.

I think it is important to point out potential overemphasis of the difficulty surrounding probable-lie comparison questions. The authors use words like "too strong", "too weak", "too hot" or "too cold" as metaphors describing potential concerns over probable-lie comparison questions. In doing so, they open examiners to increased exposure and criticism based on subjective opinions. Additionally, the underlying construct validity of the CQT is predicated on concept that comparison questions are more salient to the truthful and relevant questions more salient to the deceptive. This salience is arguably based on the test subject's perception of which question(s) pose the greatest challenge to their goal of passing the test. As long as the truthful subject has probably lied to



the comparison material, and as long as they believe they have to be truthful to all test questions to pass the test, they should produce truthful results.

Additionally the authors state; “There is also a firm guideline regarding the selection of verbs used in PLCs that correspond with the relevant questions.” The traditional reason for matching verbs to relevant questions was to provide plausibility to the PLCs, especially for new examiners. There is little rationale for having to match the PLC verbs to the relevant questions, other than to provide a logical reason for asking them. In the authors’ defense they do state that examiners should be able to convey a rationale for including these PLC questions into the test. I would have liked the authors’ to have reinforced the importance of telling the subject they have to be truthful to all questions to pass the test.

Chapter four nicely summarizes one of the most important aspects of polygraph testing- collecting good-quality data. This chapter gives examples of exemplar polygraph tracings. Students would find this very helpful in that it provides a benchmark for them while learning to collect polygraph charts. They also give examples of how to describe the sensors to the test subject, something practicing and students could adopt if needed. They also offer sections on sensor placement and troubleshooting.

Chapter five is a comprehensive review of major test data analysis (TDA) models. This chapter alone makes the book worth buying for examiners and students. The authors provide clear descriptions of fea-

tures, transformations, decision rules and normative data (where applicable) for 7-Position Scoring, 3-Position Scoring, and the Empirical Scoring System (ESS). Breaking it down by component, the authors provide pictures and descriptions of how tracings should appear and what features about the tracing are diagnostic. They describe the different scoring systems and rules, response windows, and evaluation window recommendations. They describe decision rules for single-issue investigative examinations, multiple-facet investigative examinations, and multiple-issue screening examinations. These include; the three relevant question zone comparison technique (Federal ZCT), the two relevant question technique (You-Phase), the Air Force Modified General Question Technique (AFMGQT), the Law Enforcement Pre-Employment Test, and the Utah Probable-Lie Test. The authors conclude with a thoughtful discussion of the concept of Purposeful Non-Cooperation.

Chapter six reviews the most arguably largest use of polygraph - screening of applicants, current employees, and criminal offenders. The authors tackle this thorny issue by providing some thoughtful recommendations like successive hurdles and test question target selection. They caution end-users against taking action based on test result alone and help them understand how base rates effect the numbers and types of errors. They provide some suggestions for improving pre-test interview strategies and practices. They help explain the Directed Lie Screening Test (DLST), including pretest interviewing suggestions, how to explain the directed lie comparison question (DLC),

examples of DLCs, the DLST format and rules for administration, and scoring the DLST. Then they provide an in-depth explanation for how to use the AFMGQT in multiple-issue screening including scoring, and decision rules. There is a section on the Relevant/Irrelevant technique. The chapter concludes with a section covering screening examination reports.

Most polygraph schools do a great job of teaching students to run polygraph tests. But for a new examiner, one of the hardest thing to learn is how to prepare for a case. Chapter seven does just this. It takes the examiner step by step through an investigative specific-issue test. Starting with case preparation, the authors advocate for in-depth case file review ahead of time. They encourage examiners to consider polygraph suite preparation, relevant issue consideration based on the file case facts, as well as a number of other important factors. They provide a model for the examination pretest process; introduction, overview, consent/rights, background gathering, free narratives, explaining the components, question review and introduction, and the acquaintance test. I would have liked to have seen the authors devote some more time to laying foundation for PLC questions and reinforcing to the subject they must be truthful to every question on the test to pass.

Chapter eight discusses recognition testing. The most informative part of the chapter describes the Concealed Information Test (CIT). This includes a description of instrumentation, test construction, test target selection, and test data analysis. There is a slight error in the description of the Lykken scoring system. The chapter in-

correctly states the Lykken scoring system uses the number of CITs (N) as the threshold or “cutscore” for recognition. The Lykken scoring system actually advocated for N+1 as the threshold for recognition. In defense of the authors, they provide a CIT probability table for false-positive results with a recommendation of setting that threshold at less than 10%. Users can use the table to determine the threshold or cut score needed to achieve less than 10% false positive results. Finally the chapter concludes with a summary of best practices for conducting the CIT.

Chapter nine covers scientific issues like validity and reliability. The chapter could serve as the basis for the basic polygraph school research class. There is a particularly good section on the effects of base rates on testing and how adjusting base rates effects the number and types of errors. They introduce the reader to the concept of Information Gain (IG) and how to use IG to estimate the efficacy of testing when considering base rate. They thoughtfully point out that selecting targets with extremely high or low base rates renders the polygraph test result essentially worthless. Once the base rate exceeds the productive range of base rate for a technique, the test result adds no information to the decision-making process. The chapter closes out with an interesting discussion of polygraph theories.

Gordon L. Vaughan, the author of chapter 10, is one of the most knowledgeable legal minds when it comes to polygraph law. There are few attorneys that have Gordon’s depth and breadth of legal knowledge when it comes to polygraph.



This chapter provides perhaps the most comprehensive review of polygraph law written to date. This chapter should be mandatory required reading for all examiners - probably at least annually. Gordon gives credit to New Mexico Supreme Court Justice Charles Daniels for influencing a portion of his chapter. Justice Daniels has been a strong proponent for polygraph testing and has coauthored work with Gordon involving legal issues surrounding polygraph.

Chapter 11 is titled "Advanced Topics" and addresses a number of odd-ball type problems examiners may encounter. It covers things like attaching components to subjects with amputations and injuries, testing blind subjects, considerations for people with cardiovascular abnormalities, dwarfism, hearing impaired, interpreter testing and more. There is an important reminder about ethics- a stark reminder to how important each and every polygraph test is. There is an additional section on in-depth report writing that supplements the earlier report writing section. There is a brief overview of Post-Conviction Sex Offender testing that would be informative to end-users such as parole officers and treatment providers. There is a very good section that makes recommendations for interpreter testing.

Chapter 12 discusses alternative credibility assessment technologies. I found it to be a very helpful summary of the state of these alternative techniques. Often people inquire as to the efficacy of these methods and this chapter puts answers at your fingertips. Following chapter 11 is a comprehensive glossary that any polygraph student would find helpful. There

is also three appendices that cover the Employee Polygraph Protection Law, an update of the 2011 APA Meta-Analytic Review, and example polygraph reports written by two of the profession's leading field examiners.

Miriam-Webster defines handbook as "a book capable of being conveniently carried as a ready reference manual...a concise reference book covering a particular subject." That is exactly the best description I find for this excellent text. In my opinion, this book should be standard-issue for all polygraph school students and should be on the desk of every practicing polygraph examiner and polygraph consumer.



To all of you...



For an awesome 50th Anniversary...





APA 50th Annual Seminar 2015, Chicago, IL











APA President Speech Walt Goodson

Tonight we celebrate 50 years of hosting world class seminars as well as our relentless forward progress as an association. Please give yourselves a pat on the back and have a drink because it's your dedication and hard work that has got us this far.

I'm very proud to stand before you right now. You all are a great band of brothers and sisters who have dedicated your lives to the protection of others. Clearly, you make the world a better place and it is my honor to serve you all.

Abraham Lincoln stated – Whatever you are be a good one.

In our first 50 years, our greatest threat was greed, and EPPA was the result. In our next 50 years, our greatest threat may be technology that rivals the polygraph.

So the big question of tonight is how are we not only going to survive but thrive in the coming years?

Will it be by expanding our markets by running more infidelity exams? There are 60 million married couples in the US. After the ashleymadison.com hack, we know there are at least 28 million cheaters.



Now I hope you realize I'm joking. There is also a market for bacon double cheeseburgers but this does not make them a healthy or a good idea. Infidelity exams are not the answer.

Is education the answer? For years, the APA has tried to make college degrees mandatory for polygraph examiners. Will college degrees make us better?

How about science? Many of my predecessors have argued that acceptance from the scientific community is the key to our future.

While both education and science have merit; I think it will be the consumer that determines our fate. To satisfy these customers, we must offer a more superior product than our competitors and that product is YOU!



Therefore, tonight I want to pose four questions that ask whether the APA is doing everything it can to make you the best product on the market. I think we will find success, longevity and the enrichment of our careers in the correct answers.

Question Number 1 - We have Full and Associate members to show we think college degrees are important. Does this model do more harm than good?

The polygraph is a law enforcement tool; thus, law enforcement is our largest demographic. Moreover, law enforcement agencies and the US Government do more to drive positive change in the profession than the APA. Clearly, the more members we can gain from these areas, the stronger we will be.

Unfortunately, most police agencies do not consider the importance of a college education when selecting officers to attend polygraph training.

Since this is not likely to change, the APA needs to rethink the full and associate member status, based on a degree, because there is no evidence that this membership model increases examiners with degrees. By the way, two-thirds of the APA membership does not have college degrees.

Nelson Mandela stated education is the most powerful weapon we can use to change the world and there is no question education important.

But the education that is important is continuing education. Over the years, I've seen many examiners lose their way as a result of

not pursuing continuing education instead of not having a college degree. Therefore, we need to focus on offering and incentivizing continuing education.

For decades, law enforcement across the US has used basic, intermediate, advanced and expert certificates to encourage continuing education.

I think a model like this could work for the APA as well.

Question Number 2 – Beyond education, what competencies will help us succeed?

All polygraph examiners are not created equal.

I've been fortunate to train, supervise and observe the work products of countless examiners. Some were successful in the polygraph suite and others not so much. What made the difference in the successful ones? More than education or polygraph school grades examiners with command presence outperform their counterparts who lack this skill.

Examiners with command presence have fewer inconclusive exams, higher confessions rates and are less susceptible to countermeasure attempts. Most importantly they receive fewer complaints.

What is command presence? I always thought it had to do with your appearance, but it's more than that. It's a person's confidence or swagger.

When I was a Texas Highway Patrol Trooper, I thought I had command presence. I was fit and looked good in a uniform. One eve-



ning, I stopped a very, very large man. The man stopped his car in a convenience store parking lot, climbed from his seat, unzipped his pants and began urinating in my direction. My first thought was, I hope this man is just very drunk and not a few fries short of a happy meal. I was lucky... The man was just drunk.

I strategically waited for the man to re-holster his manhood before I told him he was under arrest. My luck ran out... he refused!

Fortunately, a local deputy and dear friend of mine named Brett was in the area training a rookie and pardon the pun, they saw the whole thing.

Brett stopped to back me up, and I pulled my pistol and commanded the drunk to "get on the ground." He refused again. Thus Brett drew his pistol, and calmly stated "get on the ground or I'll shoot." Without hesitation, the drunk complied and Brett handcuffed and placed the drunk in my car. As a final insult to my pride, Brett asked if I needed directions to the jail.

The ease in which Brett arrested the drunk drove me crazy, so as I was driving him to jail, I asked why he followed Brett's orders and not mine.

The drunk replied, "simple, when the deputy said he would shoot me, the other deputy put his fingers in his ears."

Brett's command presence solved the problem. Such confidence and communication in the polygraph suite will generate more success than 10 college degrees. Thus, Brett's traits should be considered when se-

lecting new examiners.

Secondly, Brett was not born with this skill; he is a martial arts expert, and he continually pursues training. Therefore, beginning in Baltimore, training beyond TDA and formats will be offered that will make you happier, healthier and more successful in life and the polygraph suite.

Question Number 3 – Are we doing everything we can to market ourselves to our customers?

A couple of years ago, the executive leadership of the Texas DPS did not look at our polygraph unit favorably. We were like internal affairs, a necessary evil.

They only saw the negative; complaints from those who had failed their polygraphs and lost their dream of becoming a State Trooper.

We decided to stop remaining passive and market the positive side of polygraph by documenting our confessions and exonerations in a monthly summary.

After the first summary, our chain-of-command realized polygraph examiners solve more crimes and identify more child predators than entire investigative units. They were also shocked by confessions of police applicants.

Within months, they presented us with a unit award and granted us, six additional examiners, because they loved our work product and wanted more.

We didn't do anything different; we just let



them know what we have been doing for a long time.

We all could benefit from this lesson. If we properly marketed only the collective efforts of this room, it would constitute 1000s and 1000s of years of prison time for violent predators, multitudes of our good citizens exonerated and countless victims protected. This marketing strategy would show potential customers the real value of a polygraph examiner consequently increase our demand.

And finally... Question Number 4 – Are we doing this for the right reason?

An infidelity test a day will not keep EPPA away. Let me ask you all a question; what business are we really in? Here's a hint: my APA pin says polygraph to protect.

Let me ask you a question another question; why are companies like Starbucks, Apple and Zappos so successful? Is it something special about their coffee, computers and shoes? I don't think so... Others sell the same products with much less success; so what's the difference?

Starbucks CEO Howard Schultz doesn't sell coffee; he sells a third place between work and home. Steve Jobs never sold computers; he sold tools that unleash human potential and ask anyone with feet and an internet connection, Zappos sells happiness delivered.

These companies keep ahead of their competition by offering something more meaningful than just their products. Thus, we too should focus on something bigger than just

detecting lies. We should focus on what technology cannot offer, the TRUTH and PUBLIC SAFETY.

For a long time, we have chased money by conducting infidelity and other questionable exams that don't solve problems. By the way, infidelity exams are the #1 source of complaints received by the APA.

Instead, we need to encourage exams that focus on a more noble cause; PUBLIC SAFETY.

Testing sex offenders protects the public, testing criminals protects the public and screening government employees and applicants, protects the public.

We need to find innovative ways to conduct more exams that monitor drug and alcohol crimes, domestic abuse, asylum and other areas that protect the public and alleviate pressure on our courts.

These types of exams protect our good citizens and create allies in our judicial systems who will be our greatest advocates in securing our future.

Thank you all for the job you do and the professionalism in which you do it.

Please raise your glasses for a toast to another 50 great years.

God bless you all!



Special Guest Speaker Speech

Donald Krapohl



Let me begin by expressing my thanks for the APA Board for this invitation, and especially to Seminar Chair Mike Gougler, for the honor of speaking at this, the 50th annual seminar of the APA. My congratulations to our newly elected leaders. It is especially fitting that this seminar take place here in Chicago, the Windy City, the City by the Lake, the City of Broad Shoulders, the Paris on the Plains. It is a place of prose and poetry, of energy and industry. And it is the site that would repeatedly play central roles in the unfolding of the history of our profession. More about that in a moment.

Ladies and gentlemen, I've titled my talk Two Opportunities. In it I would like talk about the profession, lessons of the past and for the future. I'll try to explain how we got to where we are, what we should have learned, and about the future of credibility assessment.

The APA is beginning its 50th year. This is the 50th banquet speech members have been subjective to. If you've had the benefit of hearing some of these speeches, you already know some of them have been pretty good, and others can make you wonder whether it was worth the dinner to sit through the speech. All of them tend to be of speakers sharing their experiences. I would like to depart from this expectation this time to talk about something different: you. You, me, the profession, our shared history, and a future filled with opportunities and pitfalls.

In the past 50 years there have been many, many significant events in our field, many thousands of APA members, and perhaps tens of millions of polygraph cases. Most of the polygraph cases have been routine, but many have also been very important, and a rare few may have even impacted world events. Our rich history includes legislation, close calls, press reports, scientific advances and debates, international growth, competing technologies, waxing and waning of public support. That is a lot to cover, and it should be obvious that anyone trying to tell our story in 20 minutes or less might be a fool.

Let me begin.

Every polygraph student knows that the



advent of the polygraph in criminal investigations began in Berkeley, CA, in the early 1920s. But the seminal event that catapulted the polygraph to center stage actually happened here in Chicago, 3 miles north of where you now sit, in a nondescript garage at 2122 North Clark Street, on February 14, 1929. That was the location of St. Valentine's Day Massacre. For those who know the story, you may recall that was the day when six organized crime figures were lined up against a wall and gunned down by a competing gang over territory for their illegal liquor enterprises. Those murders made international news. The killings so outraged the city, and so embarrassed the police department, that it led to the establishment of the Scientific Crime Detection Laboratory at the Northwestern University School of Law, 2 miles north of here. To that lab would come the to-be polygraph giants Leonarde Keeler, John Larson, John Reid, Fred Inbau, and Charlie Wilson, who firmly established the polygraph as a criminal investigative tool. Keeler would eventually leave to start his own business. Where, you might ask? His office was three blocks from here on South LaSalle Street. As many of you may remember, Keeler had a small role in a famous movie, *Call Northside 777*, where he reenacted a real life polygraph examination he did of a wrongfully convicted man, calling him truthful. That was also a Chicago crime happening over on South Ashland. So, the polygraph may have been born in Berkeley, but Chicago is where it grew up and called home.

The APA came into being in the mid-1960s through the combination of five organizations: the Academy of Scientific Interrogation, the American Academy of Polygraph

Sciences, the National Board of Polygraph Examiners, the International Association of Polygraph Examiners, and the International Association for Polygraph Research. Among the most influential members of these groups, and even across the profession, Walter Atwood, Lynn Marcy, J. Kirk Barefoot. These may be names you have probably heard before. Walter, Lynn and Kirk helped shepherd the proposal to consolidate the various factions. They chaired committees, communicated with members, wrote articles in their publication, helped draft the fledgling organization's constitution. The foundation of the APA was laid by Walt and Lynn and Kirk and men like them, whose selfless service we may not always remember, but we are the beneficiaries. If you have read the 1966 APA Constitution you would see that they helped establish an organization based on standardization, professionalization, and responsible behavior. They fought the winds of personal interest to create high standards. Each of them went on to serve presidencies of the association, J. Kirk Barefoot being the first president of the APA. I heard stories about these guys in the earliest days of my career, and they would become my professional heroes. And they are here with us tonight. I would like them to stand now, and be recognized for their quiet service and lasting contribution to our profession: Ladies and gentlemen, I give you Mr. J. Kirk Barefoot, Mr. Walter Atwood and Mr. Lynn Marcy.

There were others who helped establish the APA, members who have long since passed, and we honor their memory, as well.

The first meeting of the representatives of the various associations to form the APA



took place 50 years ago last month in – you guessed it — Chicago. It was held just a 20-minute walk from here on Michigan Avenue at 11th Street. In that meeting, and later ones, they worked long and hard trying to resolve differences between the groups. They had a difficult task before them: to find common ground among a group of professionals for whom the two most common characteristics were strong opinions and stronger personalities. If examiners in the 1960s were anything like us today, those meetings would have been loud, raucous, and often contentious. The few surviving records we have from that era suggest three top arguments for NOT creating a single large association were:

1. The standards of membership of this new association would be too high.
2. There would be too many personality conflicts
3. They did not like the name American Polygraph Association.

Of course, they eventually overcame the objections, and so in 1966 we became the American Polygraph Association, and held the first of our now-50 annual seminars.

Following the establishment of the APA, there would be some rocky times. The reason: there was a lot of money to be made in a largely unregulated market. Economics came to compete with professionalism to be the powerful force. For those who have access to polygraph publications from the 1970s and 1980s you will find that, compared to today, there was a lot of attention on fighting unions and anti-polygraph legislation and critical news reporting about the polygraph, about how businesses needed

the polygraph to survive – but relatively little on research and best practices. Fierce competition among examiners caused some of them to take shortcuts, then shortcuts of shortcuts, and ultimately to practices that attracted the unwelcomed interest of legislators and scientists. Public pressure began to build to totally eliminate the polygraph because of abuses, lack of standardization, and the absence of a scientific underpinning. In fairness, a significant proportion of the abusive polygraph practices were by individuals who were not members of the APA, or members of any polygraph association for that matter, individuals tempted by the lure of profit or who succumbed to the pressure from their managers to push the polygraph beyond what it was capable of delivering. So that you will not be left to believe that all of the problems can only be laid at the doorstep of private examiners, my government colleagues of that era were not without sin: The APA published a piece in the 1970s by a well-respected government examiner who explained the rightness of his polygraph program using 7-second question spacing to test government employees, as if human physiology would conform to agency policies. In that era some federal and police programs used as many as 11 or more relevant questions in screening, one or two having to do with future intent. Several state and local police officers used the polygraph only as an interrogation prop, obtaining real and unreal confessions in the process.

Not all was so bad, though. Meanwhile, there were also several bright spots in that time, the beginnings of a few very positive trends. One especially bright spot was that there were still a lot of APA members who



held the line on maintaining high standards of practice. The Reid School, the Backster School, the Marcy School, the government school, and many of the larger polygraph companies still required their students and staff examiners to rigorously follow their testing protocols, no excuses. In the mid-70s we began to see the first of what would become a nearly 40-year stream of peer-reviewed and supportive polygraph research coming out of the University of Utah, the beginning of research at Michigan State University under Dr. Frank Horvath (another APA President) and his students, and a trickle of federally funded studies. States were passing licensing laws to ensure quality polygraph services for the protection of the public. Examiners in larger numbers were pursuing college and advanced degrees. Instrumentation started to include more electronics and more features. Some of the best of today is built on events from that period.

As we approached the 1980s there was a growing concern in the US about polygraph excesses, and by the end of the 1980s there was legislation passed that virtually eliminated private practice. The law affected all private examiners, both good and bad alike. The law did what the profession had been unwilling to do for itself, to control the excesses. This is an important lesson of history. The passage of the Employee Polygraph Protection Act, or EPPA, in 1988 was a watershed moment for the polygraph in the US. EPPA eliminated perhaps 90% of the polygraph testing in this country. It was greeted in the polygraph community with wailing and gnashing of teeth. It was seen as the end of polygraphy. Ironically, viewed from through the lens of time this restric-

tive legislation turned out to be for the betterment of the polygraph field in three important ways:

1. EPPA virtually wiped out the quacks and frauds, the incompetent, the poorly untrained, and left behind those who tended to be professionals all along.
2. Legislators appeared to be satisfied with the law, and in the subsequent 27 years there has been no other restrictive polygraph legislation. Regardless of what you may think of the EPPA law, it has forestalled any additional anti-polygraph legislation.
3. By carving out exclusions in EPPA for police and government polygraph examiners, the government tacitly recognized the polygraph as a critical tool when properly used.

This may be an object lesson for our international friends. When unregulated, abuses in the name of polygraph are inevitable when there is money at stake. If you have more than a few examiners in your country, and the polygraph is unregulated, you already know about fraud and abuses and incompetence. It is a matter of time before your government steps in with restrictive laws to control those abuses, and if public sentiment is sufficiently aroused against the polygraph, perhaps the law will make legitimate polygraph practices illegal. It does not need to end this way. Your best defense is licensure with high standards that protects the public. After all, competent and ethical polygraph practices are in everyone's interest. Make no mistake: licensure is very painful to bring about. It is about balancing interests, about egos, it's about bringing together competing forces. It is perhaps as



hard as trying to create on large polygraph association from several smaller ones, as our forebearers did to create the APA. Knowing that eventually polygraph legislation will come your way, consider how much better would be a law you help craft that controls abuses and also allows the proper use of polygraph. I offer the same suggestion to those of you in US states with no licensing laws. This is what I call our first opportunity, to bring about enforceable standards of practice that benefit everyone.

As I mentioned, many things have improved since the 1980s. An obvious example is the polygraph instrumentation. We have computers now, instruments that can do things no one could have imagined in the early days of the APA. We can video our sessions, send our electronic files around the world in seconds, display our data in new ways and with new sensors. Calipers and algorithms and derived signals are available to help us analyze the charts. Our polygraphs have report templates, pharmaceutical references, and technical guides. For the oldtimers among us, we appreciate that the new polygraphs do not weigh 35 pounds, they fit much easier on airplane storage bins, and we no longer get ink on our shirts. I love today's technology, and thank the Axciton, Limestone, Lafayette and Stoelting companies for the technological advances they have placed before us.

Technology is the second opportunity I want to discuss. It is more than a cliché to say that technology is advancing rapidly. Some of us can remember a time when fax machines were cutting edge, before Siri and Instagram, before sixth graders had mobile phones, when the Web was just something

tangled that we weaved when first we practiced to deceive. Technology can be our friend, as evidenced by the amazing things our computer polygraphs can do. They also pose a challenge if we do not properly prepare.

Let's look at the emerging forms of deception detection. Unlike voice stress, these technologies may actually prove to be valid, making them very different from what we experienced in the past. Watch for advances in brain imaging, pupillary measures, eye movement, thermal imaging, brainwave devices, cognition-based tests, and computer-interactive interviews. One or more is coming to a department or business near you.

What should be our response to these new technologies? Let me offer three possibilities:

- Response A. Ignore them. They will go away.
- Response B. Circle the wagons. Fight the technologies just like we did against voice stress.
- Response C. Recognize them. Understand their value and limitations. Add them to your practice if appropriate.

Allow me to suggest that option C is the best answer: Understand their value and limitations — Add them to your practice if appropriate. For several reasons, it is my belief that the polygraph is here to stay for a long while. It may not always look exactly like what we have now, but it will continue to be the main approach to credibility assessment for quite some time. That does not mean it will be the only technology.



Others may fit certain niche applications better. New technologies may prove helpful in a larger process, where they are added before or after polygraph testing. They may become an additional polygraph channel. We stand to benefit as a profession if we do not waste energy fighting these new tools, but rather find the right place for them.

I would like to close now with a short story. It is a story about an examiner, a hero really, that you may never have heard about, but he conducted one of those “world event” kinds of cases I mentioned in my opening remarks. He is a humble man, and I asked his permission to share his story with you here tonight.

About 15 years ago federal agents arrested FBI agent Robert Hanssen for espionage. It was international news, and considered by many as one of the biggest US spy scandals in history. Mr. Hansen’s treason led to the death of important reporting sources. What is not generally known is that Robert Hanssen was not the FBI’s prime suspect. The FBI had solid information that the actual spy was an intelligence officer with a different US government agency. As the FBI closed in on this other suspect they offered him a polygraph test, with confidence that the deceptive results would provide them leverage to secure a confession. The suspect agreed to the test. The examiner in the case was SA Ken Shull, now retired, who at the time was the Chief of the FBI’s Polygraph Section. After reviewing the case file, Ken conducted a scrupulously careful polygraph exam on the suspect. Here is where the story gets interesting. Ken’s scoring of the suspect’s charts clearly supported a decision of NDI. This is not what his fellow

agents had expected, nor were they prepared to accept. They asked Ken to review his charts again. Ken came to the same conclusion. The agents were still not convinced. They polygraph must be wrong. It must be countermeasures. They challenged Ken’s procedures. Ken didn’t back down. Finally they insisted Ken make an inconclusive call, so as not to jeopardize their case against the suspect. They reminded him that the Director of the FBI had taken a special interest in this case. Ken, at the risk of his career, told them no. The results were NDI, and he would not change the results. This did not go down well with the agents. They refused to change the direction of the investigation. They had their man, and that was that. The circumstantial evidence against their suspect was compelling on its own, but they planned other ways of catching him over the next months. And while they were in the planning stage, some information dropped into their lap that showed who the real traitor was: Robert Hanssen.

After Hanssen’s arrest appeared in the news, the innocent man called Ken to thank him. In the time before Hanssen’s arrest the innocent man had been suspended from his work. Everyone believed him to be guilty of treason. The best outcome he could see was the premature end of his career and a destroyed reputation. Now his career was back on track, and he was vindicated. He called Ken his hero.

Ken is now retired, living in Tennessee. We talk from time to time. Ken works a little, does a few tests, plays some golf, but spends much of his time raising money for charity. I tell this one story to make a point: among the professionals of this association there



are many heroes. There are some in this very room. Through your tireless commitment to profession practices you have saved the wrongly accused and brought the guilty to justice. When faced with opposition you have chosen to do the right thing when something less may have been easier. You have demonstrated personal courage even when no one will probably ever know about it. When outnumbered or outranked by others, you did not waver from your responsibility.

Tomorrow afternoon the wonderful learning experience that is the 50th APA seminar will draw to a close. We will begin to return to our regular lives and businesses

and practices. From this moment and from this place let us carry with us the sense of our history, and of our mission to pursue the truth wherever it may take us. Let us be willing to do the right thing even if puts us in opposition of others who might prefer we compromise our principles. As the early US President Andrew Jackson once famously said: One man with courage is a majority. Let us strive to remain in that majority.

Thank you, and good night.



CPS_{pro} Advantage!

We are often asked: "Why do we do, what we do?"

The answer is simple, your signals will look better and interpretations of your charts will be easier.



CPSpro Advantages:

- No Re-Centering! No lost data! You will be able to pay more attention to the examinee and allow the state-of-the-art software take control of the channels
- 7-Year warranty
- FREE Software support & upgrades
- Ability to record up to 13 channels
- Skin Conductance or Skin Resistance. Our competitors record one or the other; with us, it's your choice!
- 24-bit analog-to-digital conversion circuitry
- Medical grade LEMO and Luer inputs and connectors
- Cardiograph supports up to 215 mm Hg
- The only company that offers Skin Potential, Voice Events, Electronic Pneumos, and EDA with Laboratory-Style Finger Contoured Ag-AgCl Electrodes

We can truly stand by the notion that we have the most advanced polygraph system available with an intuitive, user friendly design.

For more information, visit us at www.StoeltingCo.com

Stoelting Co. 620 Wheat Lane, Wood Dale, IL 60191 • 1-800-860-9775 • Info@StoeltingCo.com





THE ACADEMY OF POLYGRAPH SCIENCE

8695 College Parkway, Suite 2160 • FORT MYERS, FLORIDA

www.apsPolygraphSchool.com

Contact Us For More Information and Registration!

SIMPLIFYING POLYGRAPH

For Law Enforcement,
Government and Private Examiners

The Academy of Polygraph Science's TRAINING SCHEDULE

BASIC POLYGRAPH COURSE

- Ft Myers Aug 31-Nov 6, 2015
- Ft Myers Jan 11-Mar 11, 2016
- Ft Myers Sep 12-Nov 18, 2016

BASIC EXAMINER'S SATELLITE COURSE

- Boise, Idaho Oct 5-Dec 11, 2015
- San Diego-TBD

POST CONVICTION SEXUAL OFFENDER TRAINING COURSE

- Ft Myers November 9-13, 2015
- Ft Myers Mar 14-18, 2016

ADVANCED EXAMINER COURSE

- Ft Myers Mar 21-25, 2016

For registration, tuition and general
questions, contact Instructor Ben Blalock

TEL: (630) 258-9030

E-mail: Ben@apsPolygraphSchool.com

FAX: (630) 860-9775

Academy of Polygraph Science

8695 College Parkway, Suite 2160
Fort Myers, Florida 33919

www.apsPolygraphSchool.com



"No matter what instrument you use, we'll train you. Be assured that our goal is to provide unmatched polygraph training."



POLYGRAPH PRINCIPLES MADE SIMPLE

Staying up-to-date with the ever-changing science of polygraph can sometimes be cumbersome. Yet it is imperative that our agencies and polygraph examiners are using the best standards of practice. Examinees' lives can be forever altered based upon the results of the polygraph examinations administered to them. Don't we owe it to each of them to conduct polygraph examinations utilizing the best practices and most recent research supported techniques?

The Director and Chief Instructor is Ben Blalock, who is a federally-trained polygraph examiner. He has taught a number of state and national polygraph seminars. Mr. Blalock is a polygraph school director and is a published author related to polygraph topics in various publications. Your examiners will be ready to implement these techniques immediately after training.

CALL 630.258.9030 NOW for reserved scheduling!

Polygraph Testing as a Single-Subject Scientific Experiment

By Raymond Nelson

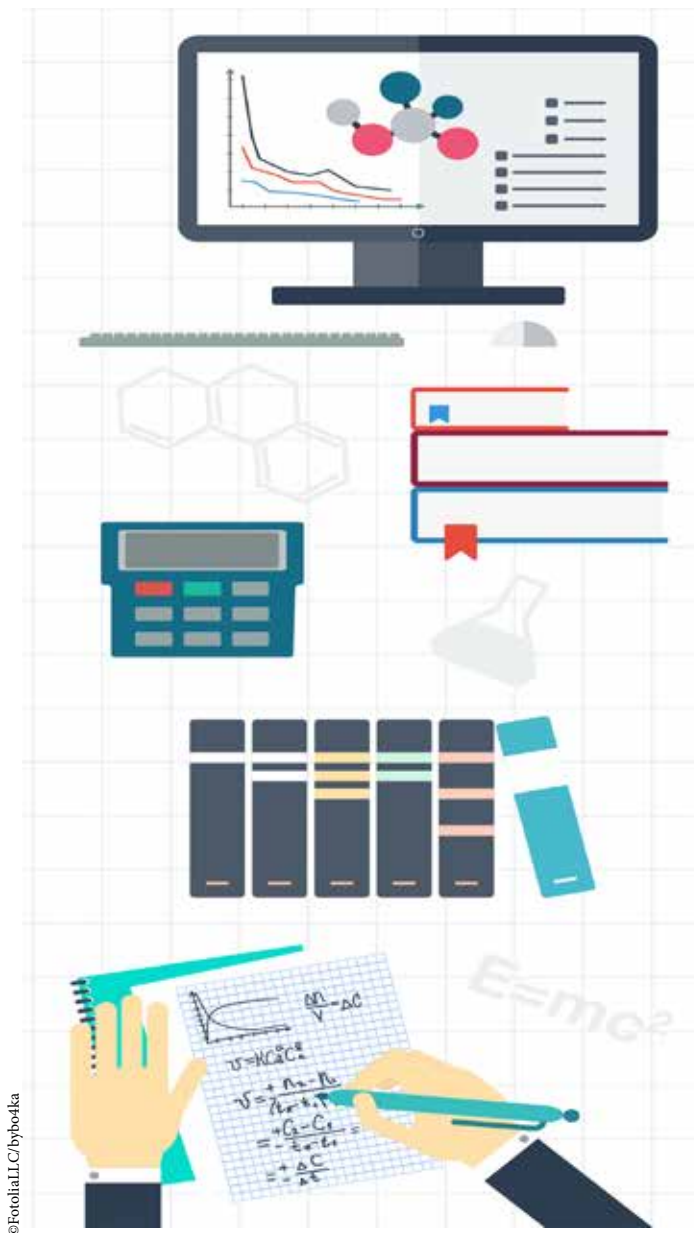

Scientific testing is a process of both classification and inference. Scientific tests can be thought of as a form of single-subject research or experiment where the test data, test scores and probabilistic test result are the evidence to support a professional opinion or conclusion to classify the test as belonging to one of multiple possible outcome categories. Professional opinions and scientific conclusions are, by definition, statements that are supported by evidence.

Evidence in scientific testing and research is commonly expressed in the form of statistical or probabilistic information based on a replicable numerical and quantitative analysis of the test data. Conclusions without objective and quantifiable supporting evidence are mere personal opinions, including when offered by a professional. Perfect deterministic solutions - immune to human behavior and immune to the effects of random chance - often do not exist for many interesting and important real-world phenomena (e.g., personality, intellectual functioning, interpersonal rapport, and the discrimination of deception and truth-telling). A statistically significant test result is

supportive of a categorical or professional conclusion, and is analogous to a statistically significant result from a scientific experiment.

Discussion

Before proceeding further it will be useful to remember that scientific conclusions are



always relative to some alternative. Scientific conclusions begin with a suggestions or hypothesis. A hypothesis is a form of conjecture, speculation or explanation for some phenomena or observation. Scientific hypothesis are, in practicality, questions that must be either supported or refuted by evidence. Personal opinion, including professional opinions that are offered without replicable quantitative analysis, can be thought of as a form of un-researched hypothesis.

Null hypothesis significance testing.

The tradition of hypothesis testing – formally called null-hypothesis significance testing – involves the comparison of the strength of evidence that a conclusion or hypothesis is correct against the strength of evidence that the conclusion or hypothesis is erroneous or that the observed data could have occurred due to random or uncontrolled causes. The formal name for the hypothesis is alternative hypothesis. The purpose of an alternative hypothesis is to attempt to provide a systematic explanation for some observed data or phenomena (i.e., how the universe works). In contrast to this is the null hypothesis which says that the observed data or phenomena may have been the result of random or uncontrolled factors. As a corollary to the notion that observed data or phenomena are due to random or non-systematic causes, the alternative hypothesis cannot be supported as a systematic explanation of the observed data or phenomena.

Stated formally, a hypothesis is supported when the null hypothesis can be rejected as not likely to have caused the observed data. Hypothesis that are supported by evidence

can be retained for further consideration as potentially useful systematic conclusions or explanations of the observed data or phenomena (i.e., how the universe works). A hypothesis is not supported if the evidence is not sufficient to reject the null hypothesis. The basic concepts of hypothesis testing can be applied to a single test observation in a manner similar to the way they are applied to a research sample. The classical, frequentist, standard of inference is that a conclusion or hypothesis is supported when the probability is sufficiently low that the observed data occurred due to causes other than the systematic conclusion, having decided a maximum tolerance for error prior to testing.

The principles of science and testing obligate us to acknowledge that there is no such thing as a deterministic or perfect test for which there will be no potential for error. The goal of a scientific test or experiment is to quantify the margin of error surrounding a possible conclusion. Hypothesis tests, regardless of whether a single case or a group of cases, begin with an explicit declaration of our tolerance for error. Neglecting this would encourage misguided expectations for perfection.

Alpha, p-value, and statistical significance.

The alpha boundary (α) is the common statistical term used to describe the level tolerance for error. Alpha is often set at $\alpha = .05$, which refers to an error tolerance of 5%. Some circumstances may warrant a more restrictive alpha boundary; in these cases $\alpha = .01$ can be used to constrain the observed error rate to a 1% level. Of course, there will be a decrease in the classification rate for



cases that are statistically significant at this level. Other circumstances may benefit from a reduction of results that are not statistically significant or inconclusive, in which case alpha can be set to $\alpha = .10$ for which the observed error rate will can be expected to be constrained to less than 10% while increasing the number of cases that are classified as statistically significant.

Alpha boundaries are always set a priori (i.e., before initiating a test or experiment). Otherwise there is an increased risk for both test errors and manipulated test outcomes. In the polygraph context, alpha is analogous to the cut-score, for which there is a cut-score for deceptive classifications along with a different cut-score for truthful classifications. Numerical cut-scores for scientific polygraph tests are calculated as a function of the desired alpha boundary and the reference model or reference data that describe the expected distributions of scores of deceptive and truthful persons. In practice, alpha boundaries and polygraph cut-scores will most often be established as a matter of agency policy.

The p-value (probability value) is the common statistical term used to describe the calculated estimate of the probability that the observed data are the result of random or uncontrolled causes. Formally, a p-value is the proportion of cases under the null hypothesis that are expected to produce a result that is similar or more extreme than the observed result. As a practical matter, results from scientific testing and research are also described categorically as to whether results are significant (i.e., statistically significant) or non-significant (i.e., not statistically significant). A result is said to be sig-

nificant at the alpha level (e.g., statistically significant at the .05 level) when the p-value (probability of error) is less than alpha (tolerance for error).

Classification: categorical results.

When probabilistic results are statistically significant we are permitted to categorically classify test results as positive or indicative of the presence of the condition or issue that is being tested. When the result is not statistically significant the result we are permitted to classify the result as negative or not indicative of the presence of the condition or issue being tested. These terms are considered objective and neutral abstractions compared to more emotionally laden terms such as pass and fail.

It is through this process of statistical inference (i.e., that observed data are not likely to be due to chance) that we can make professional conclusions based on probabilistic evidence while remaining accountable for the fact that results from scientific tests and scientific experiments are conclusions about amorphous phenomena for which neither simple and perfect deterministic observation nor direct physical/linear measurement can be achieved. Conceptually, the p-value is a statistical term that is analogous to the polygraph test score, and is calculated from the numerical test score and the statistical reference model that can be derived either empirically (i.e., either sampling or population data) or theoretically (i.e., through facts based on mathematical proof and formal logic).

Categorical results of polygraph tests have often involved descriptive terms specific to the polygraph context. A categorical conclu-



sion for positive polygraph results might be that there is deception indicated when the data differ at a statistically significant level from the statistical reference distribution for truthful persons. In polygraph screening contexts we often state more generally that there are significant reactions. Similarly, a categorical conclusion might be that there is no deception indicated when the polygraph data differ at a statistically significant level from the reference model or reference data for deceptive persons. In polygraph screening context we often state that there are no significant reactions for the sake of both simplifying and clarifying communication with others. The scientific implications are the same regardless of which labelling scheme is selected to describe the categorical test result: there is no perfect test, and all test results are fundamentally probabilistic. We use the language of statistical significance and scientific research to communicate the probabilistic and categorical polygraph test result. Categorical results of polygraph exams are supported by probabilistic calculations based on the test score and the p-value.

An examiner using a comparison question polygraph test format will actually evaluate one of two hypothesis, deception or truth-telling, depending on whether greater changes in physiological activity are loaded onto relevant or comparison stimuli. Numerical scores of positive test results of a comparison question polygraph, indicative of deception, will reject the null hypothesis that the data are not significantly different the reference model for truth-telling. Test scores that are said to be negative, indicative of truth-telling, will reject the null hypothesis that the data are not significant-

ly different from the reference model for deception. Formally, both deceptive and truthful conclusions are statistically significant (i.e., positive), though in practice classifications of truth-telling are described pragmatically as negative or indicating an absence of deception the regarding problem or issue that is being tested.

In the context of the comparison question polygraph test, the alternative hypothesis that an examinee has been deceptive is evaluated against the null hypothesis that the examinee's data do not differ significantly from the reference model or reference data for truthful persons. This is especially obvious when considering the polygraph screening context for which there is no known incident or allegation regarding the behavioral issues under investigation. Similarly, the alternative hypothesis that an examinee has been truthful will be evaluated against the null hypothesis that the observed test data do not differ significantly from the reference data or reference model for deceptive persons. A classical application of the principles of hypothesis testing to the comparison question polygraph test might evaluate the two-tailed hypothesis using a theoretical reference distribution calculated from mathematical and logical facts. In this application, the null hypothesis might be that the observed pattern of responses does not differ from the theoretical reference distribution. The alternative hypothesis might state that the observed pattern of physiological changes are systematically, non-randomly, loaded differentially onto relevant or comparison stimuli in a manner that can be shown to discriminate deception and truth-telling.



Conclusion

The principles of scientific decision making have been applied to the polygraph context for many years, ever since the first time an examiner offered a conclusion or opinion that a result was significant. Today, however, we are mindful of the fact that significance cannot be inferred visually or intuitively. Statements or conclusions about significance cannot be offered without the mathematical calculation of the level of statistical significance. Significance cannot be determined via a single presentation of a test stimulus question, and cannot be determined without first obtaining all test data required for its calculation. Discussions of significance in the scientific context belongs to the realm of quantitative and probabilistic analysis and categorical conclusion that is intimately connected with the tradition of hypothesis testing.

Categorical and probabilistic conclusions can be made for both event-specific diagnostic polygraphs, using both grand total and subtotal scores, and for multiple issue screening polygraphs, for which grand total scores are generally not used. In general, statements and conclusions of significance will become more precise when they are based on more data (i.e., more test stimuli or more iterations of the test stimuli), but will become less precise as more probabilistic conclusions are made at one time (i.e., when using subtotal scores). All computations and categorical conclusions of significance will be subject to the laws of probability. It will help the polygraph profession to advance if field practitioners can become more conversant with the basic principles of probability, scientific testing and scientific experiments. The practical goals of sci-

entific research and scientific testing will continue to involve both classification and statistical inference for as long as tests are needed and useful. Scientific tests are not expected to be perfect. They are expected to quantify the margin of error and uncertainty such that observed error rates will be within our established tolerance for error.

Although some complexities and controversies have surrounded the practice of null hypothesis significance testing, the basic principles have remained embedded in the scientific tradition such that every student in statistics from high-school through graduate school will be required to study the practical application of these basic principles. Virtually every student in every introductory statistics course will also learn about omnibus tests (i.e., F-tests and other methods) that evaluate a number of statistical hypothesis as a single hypothesis without the need for statistical corrections to manage and account for multiplicity effects, and the use of statistical corrections for multiplicity effects such as those expected when using subtotal scores on comparison question polygraphs.

Although field practitioners will never be required to complete the actual mathematical and statistical calculations, any professional who wishes to become expert in the testing an analytic aspects of the polygraph should be expected to become conversant with the language and concepts of scientific testing. A well-developed understanding of the polygraph test as a contextual application of the principles of statistical decision making can help to more effectively convey test results in ways that satisfy and educate others about the scientific basis of



the polygraph and the potential usefulness of polygraph results in legal proceedings that are in some ways constructed around similar burden of proof concepts.

In addition to a basic understanding of concepts of frequentist inference (e.g., p-value, alpha, statistical significance, etc.), it will also be useful and important for polygraph professionals to become familiar with the concepts of Bayesian inference. Bayesian inferential methods have proven their usefulness in a variety of contexts, however different a priori assumptions can lead to different a posteriori results. In practice Bayesian inference can provide probability results that

some people may find to be more intuitive than p-values and alpha boundaries. Unlike frequentist inference, Bayesian inference does not involve the use of an arbitrary alpha boundary of .05, or .01, or .10, but does involve an explicit a priori declaration of our assumption regarding the prior probability or base-rate (i.e., before testing) of each alternative conclusion. Polygraph examinations can also be thought of as a single subject Bayesian experiment, but that will have to be the subject of another publication.

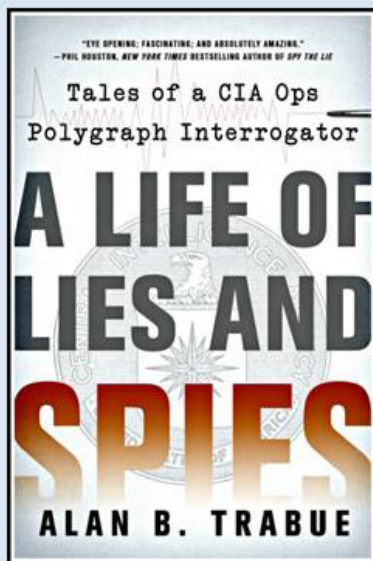

“Alan Trabue has produced a captivating collection of polygraph adventures and misadventures he lived over the course of a long CIA polygraph career. His stories strip away romantic notions about CIA overseas life to reveal the true challenges operational polygraph examiners face, how easily things can go awry, and what can happen when they do. The tales range from thrilling to amazing to funny, and some too strange not to be true. What a fascinating career Al has had, and what a riveting account he has written.”

— Donald Krapohl, former president of the American Polygraph Association

A Life of Lies and Spies highlights tales from Alan Trabue's most memorable encounters with foreign agents and the perils of polygraphing spies for the CIA. They highlight the many facets of covert ops polygraph -- intrigue, humor, danger -- and include high-speed car chases, hostile surveillance, double agents, blown clandestine meetings, tear-gassing riot police, and machine gun-armed soldiers.

Available for pre-order at Amazon.com
At bookstores June 2, 2015

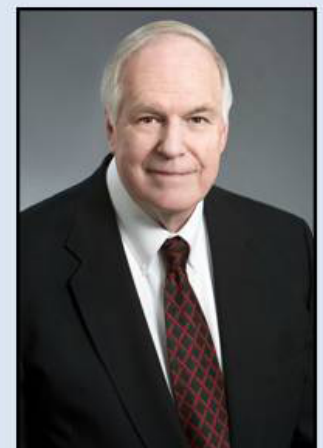

Insurance is about Peace of Mind

Complete Equity Markets, Inc. has been insuring polygraph examiners for over 25 years.

We are backed by an insurance company that's been in business for over 300 years and has defended a suit against a polygraph examiner all the way to the Supreme Court.

Limits up to 1M/3M

- * Duty to Defend
- * Polygraphists Misconduct Endorsement available (includes coverage for Sexual Abuse and Molestation)
- * Disciplinary Proceedings Coverage included
- * Personal & Advertising Injury included
- * Up to 30% in discounts
- * Discount for those insured with us for more than 7 years.
- * Private Investigation Coverage included (except surveillance) if less than 50% of your time and gross receipts from Private Investigation work under \$50,000.
- * No deductible
- * Recently lowered rates in CA, NY, NJ, HI, FL, TX & AK
- * Covers polygraph exams done as a police officer
- * Discovery Demand Defense Coverage included
- * Optional Data Breach coverage available

**Complete Equity Markets, Inc. in CA dba
Complete Equity Markets Insurance Agency, Inc.**

CASL 0D44077

Lake Zurich, IL 60047

www.cemins.com (800) 323-6234



INTERNATIONAL ACADEMY
of POLYGRAPH
Since 1981

Law Enforcement Polygraph Examiner Training



... It isn't the instrument.. It's the examiner

Chuck Michaels

2015 School Calendar Class Dates

February 16 - April 24

October 5 – December 11

10 week on campus course



1-954-771-6900

Specializing in:

- ✓ Over 95 years in Instructor Experience
- ✓ Instruction in all recognized techniques
- ✓ Computerized instrumentation
- ✓ Court Testimony Training
- ✓ Post-graduate Workshops
- ✓ Equipment Discounts

Advertising in the APA Magazine

For pricing and payment information, contact Lisa Jacocks at the APA National Office, P.O. Box 8037, Chattanooga, TN 37414, (800) APA-8037, or email - manager@polygraph.org

Then, all you need to do is send your electronic ad in .jpeg or .pdf file format, to the editor at editor@polygraph.org

Don't worry, short line items in the Buy and Sell and Upcoming Seminar sections are still free. We also publish (at no charge) in each *Magazine* a listing of upcoming polygraph training sessions for APA accredited schools.

Submissions and/or technical questions regarding your ad should be sent to editor@polygraph.org. Please note that submission deadlines are posted on page 2 of each issue.

Upgrading Membership Classifications from Associate to Full Member

If you have a college degree and you have completed a minimum of 200 polygraph examinations, request that your membership classification be upgraded from **ASSOCIATE** to **FULL MEMBER**.

In order for the Board of Directors to act upon your request, it will be necessary for you to:

Provide a **notarized** statement from your supervisor **or** knowledgeable colleague, who must be a full member of the American Polygraph Association, attesting that you have completed a minimum of 200 polygraph examinations.

Please forward the certification directly to:

APA National Office
P.O. Box 8037
Chattanooga, TN 37414

If you have any problems or questions regarding your membership, please call the National Office Manager at 800/272-8037 or 423/892-3992.



AMERICAN POLYGRAPH ASSOCIATION
APPLICATION FOR CERTIFICATE
OF
ADVANCED & SPECIALIZED TRAINING

(Application for the Certificate of Advanced and Specialized Training will be granted only to those that have completed thirty-six (36) hours of approved advanced and specialized training during the past three (3) years.

NAME: _____

ADDRESS: _____

TELEPHONE #: () _____

Membership Status: () Full Member () Life Member () Associate Member

Current Dues Paid In Full: () Yes () No

Approved Advanced & Specialized Training: Attach Certificate(s)

| Course Name | Hours | Date(s) | Location |
|-------------|-------|---------|----------|
| _____ | | | |
| _____ | | | |
| _____ | | | |
| _____ | | | |

I, _____, do hereby make application for the Certificate of Advanced & Specialized Training by the American Polygraph Association. All information contained above is true and correct to the best of my ability. I release the American Polygraph Association to conduct an inquiry or investigation as appropriate to verify said information.

Applicant

Make check payable to AMERICAN POLYGRAPH ASSOCIATION
Original Application \$50.00
Renewal \$15.00
Mail to: APA National Office, PO Box 8037, Chattanooga TN 37414-0037



APA Accredited Polygraph Schools

CALIFORNIA

Backster School Of Lie Detection

861 Sixth Ave Ste 403
San Diego, CA 92101-6379
Director: Greg Adams – 619/233-6669
E-Mail: gca1265@me.com

Marston Polygraph Academy

390 Orange Show Lane
San Bernardino, CA 92408
Director: Tom Kelly – 909/888-2988
Or 877-627-2223
E-Mail: mail@marstonpolygraphacademy.com

FLORIDA

Academy Of Polygraph Science

8695 College Parkway, Ste 2160
Fort Myers FL 33919
Director: Benjamin Blalock, 239/424-9095
E-Mail: Ben@PolygraphToday.com

Academy Of Polygraph Science Latinamerica

12945 Seminole Blvd. Ste 15
Largo, FL 33778
Director: Arno Horvath – 727-531-3782
E-Mail: polygraphacademy@hotmail.com
Website: abhpolygraphscience.com

International Academy Of Polygraph (Expired)

1835 S Perimeter Rd Ste 125
Fort Lauderdale, FL 33309
Director: Michelle Hoff
E-Mail: dci@deception.com

GEORGIA

American International Institute Of Polygraph

619 Highway 138 W Suite C
Stockbridge, GA 30281
Director: Charles E. Slupski – 770/960-1377
E-Mail: chuck@Qpolygraph.com

KENTUCKY

National Polygraph Academy

1890 Star Shoot Parkway, Ste 170-366
Lexington, KY 40509
Director: Pam Shaw
E-Mail: shaw.national@gmail.com
Website: <http://www.nationalpolygraphacademy.com>

MARYLAND

Maryland Institute Of Criminal Justice

8424 Veterans Hwy Ste 3
Millersville MD 21108-0458
Director: Billy H. Thompson – 410/987-6665
E-Mail: mdmicj@aol.com

NEW HAMPSHIRE

New England Polygraph Institute

15 Glidden Road
Moultonborough, NH 03254
Director: David J. Crawford – 603/253-8002
E-mail: kacdc@worldpath.net

PENNSYLVANIA

Academy For Scientific And Investigative Training

1704 Locust St - 2nd Fl
Philadelphia, PA 19103
Director: Nathan J. Gordon – 215/732-3349
E-Mail: truthdoctor@polygraph-training.com

*** NE CTC Polygraph Program NE CTC c/o Dept. of Military & Veteran's Affairs**

Building 8-64 Fort Indiantown Gap
Annville PA 17003-5002
Director: Elmer Criswell – 717/861-9432
E-Mail: lietestec@aol.com

SOUTH CAROLINA

***National Center For Credibility Assessment (Ncca)**

7540 Pickens Avenue
Fort Jackson, SC 29207-5000
Director: William F. Norris – 803/751-9100
E-Mail: susan.gatlin@ncca.mil

TEXAS

The Polygraph Institute

19179 Blanco Road, Suite 105 #812
San Antonio, TX 78258
Director: J. Patrick O'Burke – (210) 377-0200
Website: thepolygraphinstitute.com

Texas Department Of Public Safety Law Enforcement Polygraph School

PO Box 4087
Austin TX 78773-0450
Director: Matt Hicks, 512/424-5024
E-Mail: charles.hicks@dps.texas.gov

Veridicus International Polygraph Academy

11230 West Ave Ste 3101
San Antonio, TX 78213
Director: Yasmin Rios
E-Mail: rioscarmona@hotmail.com
Website: veridicusinc.com

VIRGINIA

Virginia School Of Polygraph

7885 Coppermine Rd
Manassas VA 20109
Director: Darryl L. DeBow – 571/435-1207
E-Mail: polygraph1@verizon.net

*City, County, State/Federal Agencies Only As Of April 2015



FOREIGN SCHOOLS

Behavioral Measures Institute, Uk, Polygraph Training Centre

Office 6
6-8 Charlotte Square
Newcastle upon Tyne, NE1 4XF
United Kingdom
Director: Donnie W. Dutton
U.S. Inquires 803-238-7999
U.K. Inquires +440-771-608-1362
E-Mail: DuttonPoly@aol.com

British Polygraph Academy

380 Uxbridge Road
London, England W5 3LH
United Kingdom
Director: Nadia Penner
UK Inquires: Don Cargill – 44 7876198762
E-Mail: don@nationalpolygraphs.co.uk

Centro De Investigacion Forense Y Control De Confianza S.c.

Rodriguez Saro #523, Int. 501-A Col. Del Valle
Del. Benito Juarez
Mexico, D.F. C.P. 03100
Director: Jaime Raul Duran Valle – 011-52-55-2455-4624
E-Mail: raul_backster@el-poligrafo.com
Website: el-poligrafo.com

Centro Mexicano De Analisis Poligrafico Y Psicologico, S.c.

Primera 23, Planta Alta
Col. Merced Gomez
Mexico D.F.
Director: Fernanda Gadea
E-Mail: fernanda@sgrh.com

Gazit International Polygraph School

29 Hamered Street Industry Building
Tel Aviv, Israel
Director: Mordechai Gazit – 972 3 575 2488
E-mail: mordi@gazit-p0ly.co.il

Instituto Latinoamericano De Poligrafia Mexico

Genova 33, Despacho 503
Col. Juarez CP 06600
Del Cuauhtemoc
Mexico DF
Director: Sandra Zambrano
E-mail: poligrafia@ilpm.com.mx

International Polygraph Studies Center

Colima No. 385-2
Colonia Roma Norte
06700 Mexico D.F.
Mexico
Director: Raymond I. Nelson
E-Mail: International@poligrafia.com.mx

Israeli Government Polygraph School

PO Box 17193
Tel-Aviv, Israel 61171
Director: Gadi Meshulam
E-Mail: igpolyschool@gmail.com

Latinamerican Institute For Credibility Assessment

Calle Los Petirrojos #438
Urbanizacion Corpac
Distrito de San Isidro
Lima, Peru
Director: Manuel Novoa – 511/226-8450

Latinamerican Polygraph Institute

730 Coral Way, Suite 102
Coral Gables, FL 33134
Director: Sidney Wise Arias – 305/441-1653
E-Mail: swarias@bellsouth.net

Mindef Centre For Credibility Assessment

Block 13, Mandai Camp 2
Mandai Road
Singapore
Director: V. Cholan
E-Mail: cholan@starnet.gov.sg

National Academy Of Polygraph Of The National Police Of Colombia

TC Jorge Zenen Lopez Guerrero
Transversal 33 No 74a-35
Sur Barrio Fatima
Bogota, Colombia
Director: Andrea del Pilar Carrillo Prieto
E-Mail: programaacademicopoligrafiapc@gmail.com

National Academy Of Training And Investigations In Polygraph Analysis

Av. Paseo de la Reforma # 364,
Colonial Juárez, Delegación Cuauhtemoc
México D.F. CP 06600
Director: Julian Flores Anda
E-Mail: gpecina07@gmail.com

National Center Of Investigation And Security Polygraph Studies Unit

Calle Cuauhtemoc # 168
Colonia Tisapan de San Angel
Mexico City, Mexico 01059
Director: Luz Del Carmen Diaz – 011/52/555/616-6273
E-Mail: ldgalindo@entermas.net

Tudor Academy

Carrera 66, No. 42-103
Barrio San Juaquin
Medellin, Colombia
Director: Charles Speagle
Website: tudoracademy.com

***City, County, State/Federal Agencies Only As Of April 2015**





APA MEMBERS

Take the most out of your membership

If you have not already done so, please go to the APA Website and register for access. We stay in contact with our membership via the email address registered on the website.

Get registered so you can continue to receive important messages and publications from the APA.



